



TransTig 1750 Puls

Operating Instructions

EN

TIG Power source

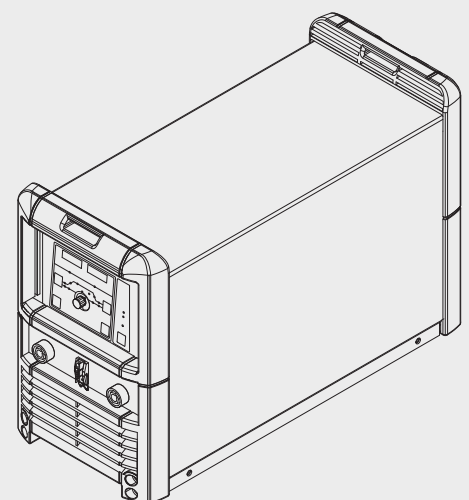

Dear reader,

Introduction

Thank you for the trust you have placed in our company and congratulations on buying this high-quality Fronius product. These instructions will help you familiarise yourself with the product. Reading the instructions carefully will enable you to learn about the many different features it has to offer. This will allow you to make full use of its advantages.

Please also note the safety rules to ensure greater safety when using the product. Careful handling of the product will repay you with years of safe and reliable operation. These are essential prerequisites for excellent results.

Contents

Safety rules.....	9
Explanation of safety symbols	9
General	9
Proper use	10
Environmental conditions.....	10
Obligations of the operator.....	10
Obligations of personnel	11
Mains connection	11
Protecting yourself and others	11
Danger from toxic gases and vapours	12
Danger from flying sparks	12
Risks from mains current and welding current.....	13
Meandering welding currents.....	14
EMC Device Classifications	14
EMC measures	14
EMF measures.....	15
Specific hazards.....	15
Factors affecting welding results.....	16
Danger from shielding gas cylinders.....	17
Danger from escaping shielding gas.....	17
Safety measures at the installation location and during transport	17
Safety measures in normal operation	18
Commissioning, maintenance and repair.....	19
Safety inspection.....	19
Disposal	19
Safety symbols.....	20
Data protection.....	20
Copyright.....	20
General information	21
General	23
Device concept	23
Functional principle.....	23
Application areas	23
Remote Control Operation	23
Control elements and connections	25
Description of the control panel	27
General	27
Safety.....	27
Description of the control panel	27
Key combinations - special functions.....	32
General	32
Displaying the software version and operating time	32
Connections, switches and mechanical components	33
Connections, switches and mechanical components	33
Installation and commissioning	35
Minimum equipment needed for welding task.....	37
General	37
TIG DC welding.....	37
MMA welding	37
Before installation and commissioning.....	38
Safety.....	38
Utilisation for intended purpose	38
Setup regulations	38
Mains connection	38

Generator-powered operation	38
Start-up	40
Safety	40
General	40
Connecting the gas cylinder	40
Establishing a ground (earth) connection to the workpiece	40
Connecting the welding torch	41
Welding	43
TIG modes	45
Safety	45
Symbols and their explanations	45
2-step mode	46
Spot welding	46
4-step mode	47
Special 4-step: variant 1	48
Overloading of the tungsten electrode	49
Overloading of the tungsten electrode	49
TIG welding	50
Safety	50
Welding parameters	50
Preparations	51
TIG welding	51
Igniting the arc	52
Igniting the arc using high frequency(HF ignition)	52
Touchdown ignition	53
End of welding	54
Special functions and options	55
Arc break watchdog function	55
Ignition time-out function	55
TIG pulsing	55
Tacking function	56
MMA welding	58
Safety	58
Preparations	58
MMA welding	58
HotStart function	59
Anti-stick function	60
Setup settings	61
The Setup menu	63
General	63
Overview	63
Shielding gas setup menu	64
General	64
Accessing the Shielding gas setup menu	64
Changing welding parameters	64
Exiting the Shielding gas setup menu	64
Welding parameters in the Shielding gas setup menu	64
TIG setup menu	66
Accessing the TIG setup menu	66
Changing welding parameters	66
Exiting the TIG setup menu	66
Welding parameters in the TIG setup menu	66
TIG setup menu: level 2	69
Accessing the TIG setup menu: level 2	69
Changing welding parameters	69
Exiting the TIG setup menu: level 2	69
Welding parameters in the TIG setup menu: level 2	69
Rod electrode setup menu	71
Accessing the Rod electrode setup menu	71
Changing welding parameters	71

Exiting the Rod electrode setup menu	71
Welding parameters in the Rod electrode setup menu	71
Rod electrode setup menu: level 2	73
Accessing the Rod electrode setup menu level 2	73
Changing welding parameters	73
Exiting the Rod electrode setup menu: level 2	73
Welding parameters in the Rod electrode setup menu level 2	73
Troubleshooting and maintenance	75
Troubleshooting	77
General	77
Safety	77
Displayed service codes	77
Power source	78
Care, maintenance and disposal	80
General	80
Safety	80
At every start-up	80
Every 2 months	80
Every 6 months	80
Disposal	80
Appendix	81
Technical data	83
Special voltages	83
TransTig 1750 Puls	83
Spare parts list	84
.....	84
Circuit diagram	85
.....	85

Safety rules

Explanation of safety symbols



DANGER! Indicates immediate and real danger. If it is not avoided, death or serious injury will result.



WARNING! Indicates a potentially dangerous situation. Death or serious injury may result if appropriate precautions are not taken.



CAUTION! Indicates a situation where damage or injury could occur. If it is not avoided, minor injury and/or damage to property may result.



NOTE! Indicates a risk of flawed results and possible damage to the equipment.

IMPORTANT! Indicates tips for correct operation and other particularly useful information. It does not indicate a potentially damaging or dangerous situation.

If you see any of the symbols depicted in the "Safety rules" chapter, special care is required.

General



The device is manufactured using state-of-the-art technology and according to recognised safety standards. If used incorrectly or misused, however, it can cause:

- injury or death to the operator or a third party,
- damage to the device and other material assets belonging to the operating company,
- inefficient operation of the device.

All persons involved in commissioning, operating, maintaining and servicing the device must:

- be suitably qualified,
- have sufficient knowledge of welding and
- read and follow these operating instructions carefully.

The operating instructions must always be at hand wherever the device is being used. In addition to the operating instructions, attention must also be paid to any generally applicable and local regulations regarding accident prevention and environmental protection.

All safety and danger notices on the device

- must be in a legible state,
- must not be damaged,
- must not be removed,
- must not be covered, pasted or painted over.

For the location of the safety and danger notices on the device, refer to the section headed "General" in the operating instructions for the device. Before switching on the device, rectify any faults that could compromise safety.

This is for your personal safety!

Proper use



The device is to be used exclusively for its intended purpose.

The device is intended solely for the welding processes specified on the rating plate.

Any use above and beyond this purpose is deemed improper. The manufacturer shall not be held liable for any damage arising from such usage.

Proper use includes:

- carefully reading and following all the instructions given in the operating instructions
- studying and obeying all safety and danger notices carefully
- performing all stipulated inspection and maintenance work.

Never use the device for the following purposes:

- Thawing out pipes
- Charging batteries
- Starting engines

The device is designed for use in industry and the workshop. The manufacturer accepts no responsibility for any damage caused through use in a domestic setting.

The manufacturer likewise accepts no liability for inadequate or incorrect results.

Environmental conditions



Operation or storage of the device outside the stipulated area will be deemed as not in accordance with the intended purpose. The manufacturer shall not be held liable for any damage arising from such usage.

Ambient temperature range:

- during operation: -10 °C to + 40 °C (14 °F to 104 °F)
- during transport and storage: -20 °C to +55 °C (-4 °F to 131 °F)

Relative humidity:

- up to 50% at 40 °C (104 °F)
- up to 90% at 20 °C (68 °F)

The surrounding air must be free from dust, acids, corrosive gases or substances, etc.

Can be used at altitudes of up to 2000 m (6561 ft. 8.16 in.)

Obligations of the operator



The operator must only allow persons to work with the device who:

- are familiar with the fundamental instructions regarding safety at work and accident prevention and have been instructed in how to use the device
- have read and understood these operating instructions, especially the section "safety rules", and have confirmed as much with their signatures
- are trained to produce the required results.

Checks must be carried out at regular intervals to ensure that operators are working in a safety-conscious manner.

Obligations of personnel



Before using the device, all persons instructed to do so undertake:

- to observe the basic instructions regarding safety at work and accident prevention
- to read these operating instructions, especially the "Safety rules" section and sign to confirm that they have understood them and will follow them.

Before leaving the workplace, ensure that people or property cannot come to any harm in your absence.

Mains connection

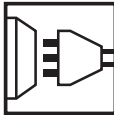

Devices with a higher rating may affect the energy quality of the mains due to their current consumption.

This may affect a number of types of device in terms of:

- connection restrictions
- criteria with regard to the maximum permissible mains impedance ^{*)}
- criteria with regard to the minimum short-circuit power requirement ^{*)}



^{*)} at the interface with the public grid
see Technical Data

In this case, the plant operator or the person using the device should check whether the device may be connected, where appropriate by discussing the matter with the power supply company.

NOTE! Ensure that the mains connection is earthed properly

Protecting yourself and others



Persons involved with welding expose themselves to numerous risks, e.g.:

- flying sparks and hot pieces of metal
- arc radiation, which can damage eyes and skin



- hazardous electromagnetic fields, which can endanger the lives of those using cardiac pacemakers



- risk of electrocution from mains current and welding current



- greater noise pollution



- harmful welding fumes and gases

Anyone working on the workpiece while welding is in progress must wear suitable protective clothing with the following properties:

- flame-resistant
- insulating and dry
- covers the whole body, is undamaged and in good condition
- safety helmet
- trousers with no turn-ups



- Protective clothing refers to a variety of different items. Operators should:
- protect eyes and face from UV rays, heat and sparks using a protective visor and regulation filter.
 - wear regulation protective goggles with side protection behind the protective visor.
 - wear stout footwear that provides insulation even in wet conditions.
 - protect the hands with suitable gloves (electrically insulated and providing protection against heat).
 - wear ear protection to reduce the harmful effects of noise and to prevent injury.



- Keep all persons, especially children, out of the working area while any devices are in operation or welding is in progress. If, however, there are people in the vicinity,
- make them aware of all the dangers (risk of dazzling by the arc, injury from flying sparks, harmful welding fumes, noise, possible risks from mains current and welding current, etc.),
 - provide suitable protective equipment or
 - erect suitable safety screens/curtains.

Danger from toxic gases and vapours



The fumes produced during welding contain harmful gases and vapours.

Welding fumes contain substances that may, under certain circumstances, cause birth defects or cancer.

Keep your face away from welding fumes and gases.

Fumes and hazardous gases

- must not be breathed in
- must be extracted from the working area using appropriate methods.

Ensure an adequate supply of fresh air with a ventilation rate of at least 20 m³/hour.

Otherwise, a protective mask with an air supply must be worn.

Close the shielding gas cylinder valve or main gas supply if no welding is taking place.

If there is any doubt about whether the extraction capacity is sufficient, the measured toxic emission values should be compared with the permissible limit values.

Amongst others, the following components are responsible for the degree of toxicity of welding fumes:

- Metals used for the workpiece
- Electrodes
- Coatings
- Cleaners, degreasers, etc.

The relevant material safety data sheets and manufacturer's specifications for the listed components should therefore be studied carefully.

Flammable vapours (e.g. solvent fumes) should be kept away from the arc's radiation area.

Danger from flying sparks



Flying sparks may cause fires or explosions.

Never weld close to flammable materials.

Flammable materials must be at least 11 metres (36 ft. 1.07 in.) away from the arc, or alternatively covered with an approved cover.

A suitable, tested fire extinguisher must be available and ready for use.

Sparks and pieces of hot metal may also get into adjacent areas through small gaps or openings. Take appropriate precautions to prevent any danger of injury or fire.

Welding must not be performed in areas that are subject to fire or explosion or near sealed tanks, vessels or pipes unless these have been prepared in accordance with the relevant national and international standards.

Do not carry out welding on containers that are being or have been used to store gases, propellants, mineral oils or similar products. Residues pose an explosive hazard.

Risks from mains current and welding current



An electric shock is potentially life threatening and can be fatal.

Do not touch live parts either inside or outside the device.



During MIG/MAG welding and TIG welding, the welding wire, the wirepool, the feed rollers and all pieces of metal that are in contact with the welding wire are live.

Always set the wirefeeder up on a sufficiently insulated surface or use a suitable, insulated wirefeeder holder.

Make sure that you and others are protected with an adequately insulated, dry temporary backing or cover for the earth or ground potential. This temporary backing or cover must extend over the entire area between the body and the earth or ground potential.

All cables and leads must be secured, undamaged, insulated and adequately dimensioned. Replace loose connections and scorched, damaged or inadequately dimensioned cables and leads immediately.

Use the handle to ensure the power connections are tight before every use. In the case of power cables with a bayonet connector, rotate the power cable around the longitudinal axis by at least 180° and pre-load.

Do not wrap cables or leads around the body or parts of the body.

The electrode (rod electrode, tungsten electrode, welding wire, etc.) must

- never be immersed in liquid for cooling
- Never touch the electrode when the power source is switched on.

Double the open circuit voltage of a power source can occur between the welding electrodes of two power sources. Touching the potentials of both electrodes at the same time may be fatal under certain circumstances.

Arrange for the mains cable to be checked regularly by a qualified electrician to ensure the ground conductor is functioning properly.

The device must only be operated on a mains supply with a ground conductor and a socket with a ground conductor contact.

Operating the device on a grid without a ground conductor and in a socket without a ground conductor contact will be deemed gross negligence. The manufacturer shall not be held liable for any damage arising from such usage.

If necessary, provide an adequate earth connection for the workpiece.

Switch off unused devices.

Wear a safety harness if working at height.

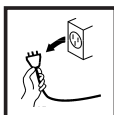

Before working on the device, switch it off and pull out the mains plug.

Attach a clearly legible and easy-to-understand warning sign to the device to prevent anyone from plugging the mains plug back in and switching it on again.

After opening the device:

- Discharge all live components
- Ensure that all components in the device are de-energised

If work on live parts is required, appoint a second person to switch off the main switch at the right moment.

Meandering welding currents



If the following instructions are ignored, meandering welding currents can develop with the following consequences:

- Fire hazard
- Overheating of parts connected to the workpiece
- Irreparable damage to ground conductors
- Damage to device and other electrical equipment

Ensure that the workpiece is held securely by the workpiece clamp.

Attach the workpiece clamp as close as possible to the area that is to be welded.

If the floor is electrically conductive, the device must be set up with sufficient insulating material to insulate it from the floor.

If distribution boards, twin-head mounts, etc., are being used, note the following: The electrode of the welding torch / electrode holder that is not used is also live. Make sure that the welding torch / electrode holder that is not used is kept sufficiently insulated.

In the case of automated MIG/MAG applications, ensure that only an insulated wire electrode is routed from the welding wire drum, large wirefeeder spool or wirespool to the wire-feed unit.

EMC Device Classifications



Devices in emission class A:

- Are only designed for use in industrial settings
- Can cause line-bound and radiated interference in other areas

Devices in emission class B:

- Satisfy the emissions criteria for residential and industrial areas. This is also true for residential areas in which the energy is supplied from the public low-voltage mains.

EMC device classification as per the rating plate or technical data.

EMC measures



In certain cases, even though a device complies with the standard limit values for emissions, it may affect the application area for which it was designed (e.g. when there is sensitive equipment at the same location, or if the site where the device is installed is close to either radio or television receivers).

If this is the case, then the operator is obliged to take appropriate action to rectify the situation.

Check and evaluate the immunity to interference of nearby devices according to national and international regulations. Examples of equipment that may be susceptible to interference from the device include:

- Safety devices
 - Power, signal and data transfer lines
 - IT and telecommunications devices
 - Measuring and calibrating devices
-

Supporting measures for avoidance of EMC problems:

1. Mains supply
 - If electromagnetic interference arises despite correct mains connection, additional measures are necessary (e.g. use a suitable line filter).
2. Welding power leads
 - must be kept as short as possible
 - must run close together (to avoid EMF problems)
 - must be kept well apart from other leads
3. Equipotential bonding
4. Earthing of the workpiece
 - If necessary, establish an earth connection using suitable capacitors.
5. Shielding, if necessary
 - Shield off other nearby devices
 - Shield off entire welding installation

EMF measures



- Electromagnetic fields may pose as yet unknown risks to health:
- effects on the health of others in the vicinity, e.g. wearers of pacemakers and hearing aids
 - wearers of pacemakers must seek advice from their doctor before approaching the device or any welding that is in progress
 - for safety reasons, keep distances between the welding cables and the welder's head/torso as large as possible
 - do not carry welding cables and hosepacks over the shoulders or wind them around any part of the body

Specific hazards



- Keep hands, hair, clothing and tools away from moving parts. For example:
- Fans
 - Cogs
 - Rollers
 - Shafts
 - Wirespools and welding wires

Do not reach into the rotating cogs of the wire drive or into rotating drive components.

Covers and side panels may only be opened/removed while maintenance or repair work is being carried out.

During operation

- Ensure that all covers are closed and all side panels are fitted properly.
- Keep all covers and side panels closed.



The welding wire emerging from the welding torch poses a high risk of injury (piercing of the hand, injuries to the face and eyes, etc.).



Therefore always keep the welding torch away from the body (devices with wire-feed unit) and wear suitable protective goggles.



Never touch the workpiece during or after welding - risk of burns.

Slag can jump off cooling workpieces. The specified protective equipment must therefore also be worn when reworking workpieces, and steps must be taken to ensure that other people are also adequately protected.

Welding torches and other parts with a high operating temperature must be allowed to cool down before handling.



Special provisions apply in areas at risk of fire or explosion - observe relevant national and international regulations.



Power sources for work in areas with increased electric risk (e.g. near boilers) must carry the "Safety" sign. However, the power source must not be located in such areas.



Risk of scalding from escaping coolant. Switch off cooling unit before disconnecting coolant flow or return lines.



Observe the information on the coolant safety data sheet when handling coolant. The coolant safety data sheet may be obtained from your service centre or downloaded from the manufacturer's website.



Use only suitable load-carrying equipment supplied by the manufacturer when transporting devices by crane.

- Hook chains and/or ropes onto all suspension points provided on the load-carrying equipment.
- Chains and ropes must be at the smallest angle possible to the vertical.
- Remove gas cylinder and wire-feed unit (MIG/MAG and TIG devices).

If the wire-feed unit is attached to a crane holder during welding, always use a suitable, insulated wirefeeder hoisting attachment (MIG/MAG and TIG devices).

If the device has a carrying strap or handle, this is intended solely for carrying by hand. The carrying strap is not to be used if transporting with a crane, counterbalanced lift truck or other mechanical hoist.

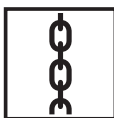

All lifting accessories (straps, handles, chains, etc.) used in connection with the device or its components must be tested regularly (e.g. for mechanical damage, corrosion or changes caused by other environmental factors). The testing interval and scope of testing must comply with applicable national standards and directives as a minimum.



Odourless and colourless shielding gas may escape unnoticed if an adapter is used for the shielding gas connection. Prior to assembly, seal the device-side thread of the adapter for the shielding gas connection using suitable Teflon tape.

Factors affecting welding results

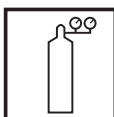

The following requirements with regard to shielding gas quality must be met if the welding system is to operate in a correct and safe manner:

- Size of solid matter particles < 40 μm
- Pressure dew point < -20 °C
- Max. oil content < 25 mg/m³

Filters must be used if necessary.



NOTE! There is an increased risk of soiling if ring mains are being used

Danger from shielding gas cylinders



Shielding gas cylinders contain gas under pressure and can explode if damaged. As the shielding gas cylinders are part of the welding equipment, they must be handled with the greatest of care.

Protect shielding gas cylinders containing compressed gas from excessive heat, mechanical impact, slag, naked flames, sparks and arcs.

Mount the shielding gas cylinders vertically and secure according to instructions to prevent them falling over.

Keep the shielding gas cylinders well away from any welding or other electrical circuits.

Never hang a welding torch on a shielding gas cylinder.

Never touch a shielding gas cylinder with an electrode.

Risk of explosion - never attempt to weld a pressurised shielding gas cylinder.

Only use shielding gas cylinders suitable for the application in hand, along with the correct and appropriate accessories (regulator, hoses and fittings). Only use shielding gas cylinders and accessories that are in good condition.

Turn your face to one side when opening the valve of a shielding gas cylinder.

Close the shielding gas cylinder valve if no welding is taking place.

If the shielding gas cylinder is not connected, leave the valve cap in place on the cylinder.

The manufacturer's instructions must be observed as well as applicable national and international regulations for shielding gas cylinders and accessories.

Danger from escaping shielding gas



Risk of suffocation from the uncontrolled escape of shielding gas

Shielding gas is colourless and odourless and, in the event of a leak, can displace the oxygen in the ambient air.

- Ensure an adequate supply of fresh air with a ventilation rate of at least 20 m³/hour.
- Observe safety and maintenance instructions on the shielding gas cylinder or the main gas supply.
- Close the shielding gas cylinder valve or main gas supply if no welding is taking place.
- Check the shielding gas cylinder or main gas supply for uncontrolled gas leakage before every start-up.

Safety measures at the installation location and during transport

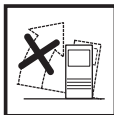

A device toppling over could easily kill someone. Place the device on a solid, level surface such that it remains stable

- The maximum permissible tilt angle is 10°.



Special regulations apply in rooms at risk of fire or explosion

- Observe relevant national and international regulations.

Use internal directives and checks to ensure that the workplace environment is always clean and clearly laid out.

Only set up and operate the device in accordance with the degree of protection shown on the rating plate.

When setting up the device, ensure there is an all-round clearance of 0.5 m (1 ft. 7.69 in.) to ensure that cooling air can flow in and out freely.

When transporting the device, observe the relevant national and local guidelines and accident prevention regulations. This applies especially to guidelines regarding the risks arising during transport.

Do not lift or transport operational devices. Switch off devices before transport or lifting.

Before transporting the device, allow coolant to drain completely and detach the following components:

- Wirefeeder
 - Wirespool
 - Shielding gas cylinder
-

After transporting the device, the device must be visually inspected for damage before commissioning. Any damage must be repaired by trained service technicians before commissioning the device.

Safety measures in normal operation



Only operate the device when all safety devices are fully functional. If the safety devices are not fully functional, there is a risk of

- injury or death to the operator or a third party
 - damage to the device and other material assets belonging to the operator
 - inefficient operation of the device
-

Any safety devices that are not functioning properly must be repaired before switching on the device.

Never bypass or disable safety devices.

Before switching on the device, ensure that no one is likely to be endangered.

Check the device at least once a week for obvious damage and proper functioning of safety devices.

Always fasten the shielding gas cylinder securely and remove it beforehand if the device is to be transported by crane.

Only the manufacturer's original coolant is suitable for use with our devices due to its properties (electrical conductivity, anti-freeze agent, material compatibility, flammability, etc.).

Only use suitable original coolant from the manufacturer.

Do not mix the manufacturer's original coolant with other coolants.

Only connect the manufacturer's system components to the cooling circuit.

The manufacturer accepts no liability for damage resulting from use of other system components or a different coolant. In addition, all warranty claims will be forfeited.

Cooling Liquid FCL 10/20 does not ignite. The ethanol-based coolant can ignite under certain conditions. Transport the coolant only in its original, sealed containers and keep well away from any sources of ignition.

Used coolant must be disposed of properly in accordance with the relevant national and international regulations. The coolant safety data sheet may be obtained from your service centre or downloaded from the manufacturer's website.

Check the coolant level before starting to weld, while the system is still cool.

Commissioning, maintenance and repair



It is impossible to guarantee that bought-in parts are designed and manufactured to meet the demands made of them, or that they satisfy safety requirements.

- Use only original spare and wearing parts (also applies to standard parts).
- Do not carry out any modifications, alterations, etc. to the device without the manufacturer's consent.
- Components that are not in perfect condition must be replaced immediately.
- When ordering, please give the exact designation and part number as shown in the spare parts list, as well as the serial number of your device.

The housing screws provide the ground conductor connection for earthing the housing parts.

Only use original housing screws in the correct number and tightened to the specified torque.

Safety inspection



The manufacturer recommends that a safety inspection of the device is performed at least once every 12 months.

The manufacturer recommends that the power source be calibrated during the same 12-month period.

A safety inspection should be carried out by a qualified electrician

- after any changes are made
- after any additional parts are installed, or after any conversions
- after repair, care and maintenance has been carried out
- at least every twelve months.

For safety inspections, follow the appropriate national and international standards and directives.

Further details on safety inspection and calibration can be obtained from your service centre. They will provide you on request with any documents you may require.

Disposal



Do not dispose of this device with normal domestic waste! To comply with the European Directive on Waste Electrical and Electronic Equipment and its implementation as national law, electrical equipment that has reached the end of its life must be collected separately and returned to an approved recycling facility. Any device that you no longer require must either be returned to your dealer or given to one of the approved collection and recycling facilities in your area. Ignoring this European Directive may have potentially adverse effects on the environment and your health!

Safety symbols

Devices with the CE mark satisfy the essential requirements of the low-voltage and electromagnetic compatibility directives (e.g. relevant product standards of the EN 60 974 series).

Fronius International GmbH hereby declares that the device is compliant with Directive 2014/53/EU. The full text on the EU Declaration of Conformity can be found at the following address: <http://www.fronius.com>

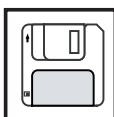

Devices marked with the CSA test mark satisfy the requirements of the relevant standards for Canada and the USA.

Data protection

The user is responsible for the safekeeping of any changes made to the factory settings. The manufacturer accepts no liability for any deleted personal settings.

Copyright

Copyright of these operating instructions remains with the manufacturer.

The text and illustrations are all technically correct at the time of printing. We reserve the right to make changes. The contents of the operating instructions shall not provide the basis for any claims whatsoever on the part of the purchaser. If you have any suggestions for improvement, or can point out any mistakes that you have found in the instructions, we will be most grateful for your comments.

General information

Device concept



TransTig 1750 Puls

The TransTig (TT) 1750 Puls TIG power source is a microprocessor-controlled inverter power source.

The modular design and potential for system add-ons ensure a high degree of flexibility.

The power source is generator-compatible and exceptionally sturdy in day-to-day operation due to its protected controls and powder-coated housing.

The straightforward operating concept means the welder can see the key functions at a glance and adjust them accordingly.

A standardised LocalNet interface makes it easy to connect to digital system add-ons (e.g. remote control units, etc.).

The power source has a TIG pulsed arc function with a wide frequency range.

Functional principle

The central control unit of the power source controls the whole welding process. During the welding process, actual readings are taken all the time and the device responds immediately to any changes. Control algorithms ensure that the specified target status is maintained.

This results in:

- a precise welding process,
- a high degree of reproducibility of all results,
- excellent weld properties.

Application areas

The power source is used for repair and maintenance tasks in production and manufacturing environments.

Remote Control Operation

The power source TransTig 1750 Puls can be operated with the following remote controls:

- TR 1200
- TR 1300
- TR 1600
- TR 2000
- TR 2200-F
- TR 2200-FM

Control elements and connections

Description of the control panel

General

The key feature of the control panel is the logical way in which the controls are arranged. All the main parameters needed for day-to-day working can easily be:

- selected using the buttons
- altered with the adjusting dial
- shown during welding on the digital display





Safety



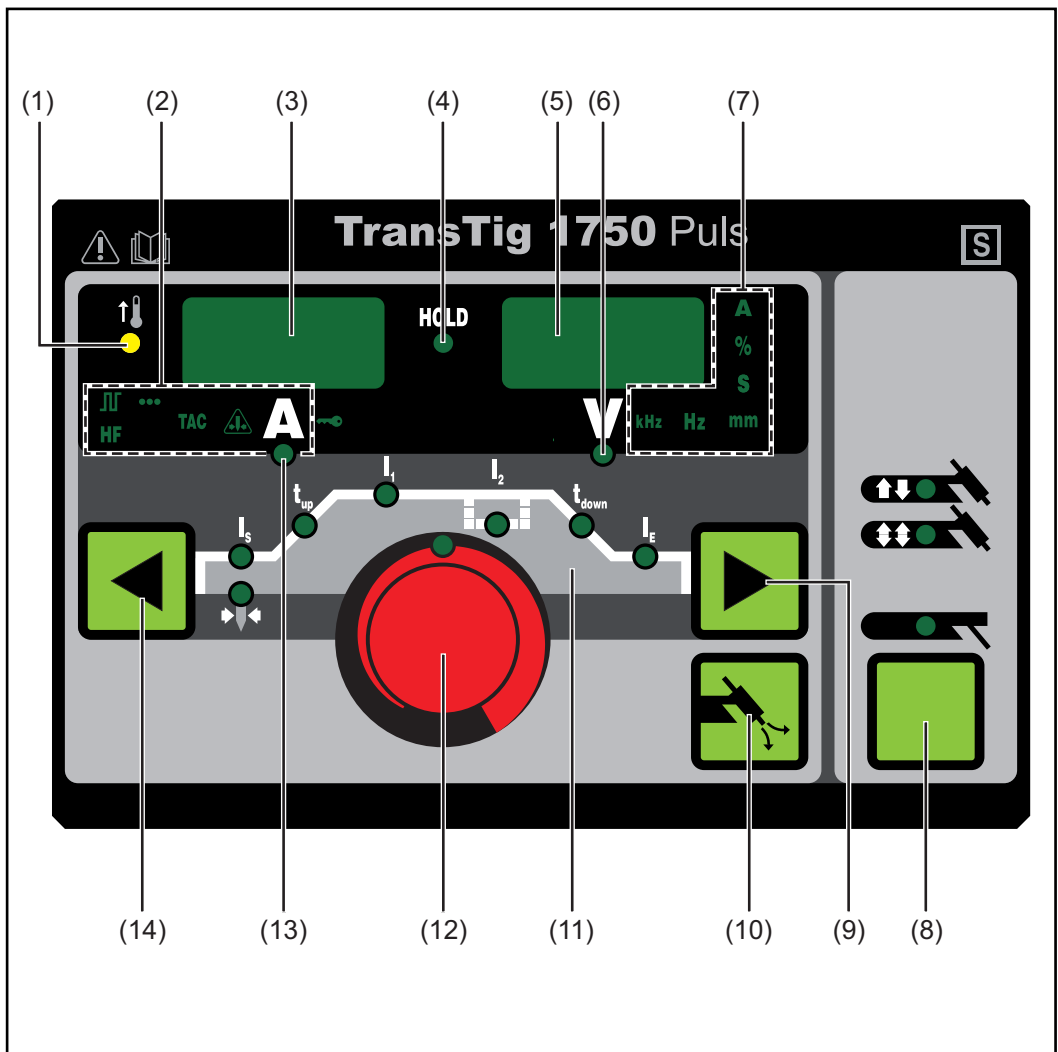





! **WARNING!** Operating the equipment incorrectly can cause serious injury and damage. Do not use the functions described until you have thoroughly read and understood the following documents:

- these operating instructions
- all the operating instructions for the system components, especially the safety rules

Description of the control panel



Item	Designation
(1)	<p>Overtemperature indicator lights up if the power source overheats (e.g. because the duty cycle has been exceeded). See the "Troubleshooting" section for more information.</p>
(2)	<p>Special indicators</p> <p> Pulse indicator lights up when the F-P setup parameter has been set to a pulse frequency</p> <p> Spot welding indicator lights up when the SPt setup parameter has been set to a spot welding time</p> <p> Tacking indicator lights up when the tAC setup parameter has been set to a period of time</p> <p> Electrode overload indicator lights up if the tungsten electrode is overloaded. See section on TIG welding under "Welding" for more information on the electrode overload indicator.</p> <p> HF (high-frequency) ignition indicator lights up when the HFt setup parameter has been set to an interval for the high-frequency pulses</p>
(3)	<p>Left digital display</p>
(4)	<p>HOLD indicator at the end of each welding operation, the actual values for the welding current and voltage are stored and the "Hold" indicator lights up.</p> <p>The Hold indicator refers to the last value reached by the main current I_1. As soon as any other welding parameter is selected, the Hold indicator goes out. The Hold values will, however, continue to be available if welding parameter I1 is selected again.</p> <p>The Hold indicator is cleared when:</p> <ul style="list-style-type: none"> - a new welding operation is started - the welding current I_1 is adjusted - the mode is changed - the process is changed <p>IMPORTANT! Hold values are not output if:</p> <ul style="list-style-type: none"> - the main current phase was never reached, or - a pedal remote control was used
(5)	<p>Right digital display</p>
(6)	<p>Welding voltage indicator lights up when parameter I_1 is selected The actual welding voltage value is shown on the right digital display during welding.</p> <p>Before welding, the following appears on the right digital display:</p> <ul style="list-style-type: none"> - 0.0 if a TIG welding mode is selected - ~ 93 V if a MMA welding mode is selected (after a delay of 3 seconds; the average value for the pulsed open-circuit voltage is ~ 93 V)
(7)	<p>Unit indicators</p>

Item	Designation												
	<p> kHz indicator lights up when the F-P setup parameter is selected if the value entered for the pulse frequency ≥ 1000 Hz</p>												
	<p> Hz indicator lights up when:</p> <ul style="list-style-type: none"> - the F-P setup parameter is selected if the value entered for the pulse frequency < 1000 Hz - the ACF setup parameter has been selected 												
	<p> A indicator</p>												
	<p> % indicator lights up when the I_S, I_2 and I_E welding parameters and the dcY, I-G and HCU setup parameters have been selected</p>												
	<p> s indicator lights up when the tup and tdown welding parameters plus the following setup parameters have been selected:</p> <table border="0" style="margin-left: 40px;"> <tr> <td>GPr</td> <td>tAC</td> <td>Hft</td> </tr> <tr> <td>G-L</td> <td>t-S</td> <td>lto</td> </tr> <tr> <td>G-H</td> <td>t-E</td> <td>Arc</td> </tr> <tr> <td>SPt</td> <td>Hti</td> <td></td> </tr> </table>	GPr	tAC	Hft	G-L	t-S	lto	G-H	t-E	Arc	SPt	Hti	
GPr	tAC	Hft											
G-L	t-S	lto											
G-H	t-E	Arc											
SPt	Hti												
	<p> mm indicator</p>												
(8)	<p>Mode button for selecting the mode:</p> <ul style="list-style-type: none">  2-step mode  4-step mode  MMA welding 												
(9)	<p>Right Parameter Selection button for selecting welding parameters within the welding parameters overview (11)</p> <p>When a welding parameter is selected, the LED on the relevant parameter symbol lights up.</p>												
(10)	<p>Gas Test button for setting the required shielding gas flow rate on the pressure regulator When the Gas Test button is pressed, shielding gas will flow for 30 s. Press the button again to stop the gas flow prematurely.</p>												

Item	Designation
------	-------------

(11)	Welding parameters overview
------	------------------------------------

The welding parameters overview contains the most important welding parameters to be used when welding. The sequence of welding parameters follows a clothesline structure. Use the left and right Parameter Selection buttons to navigate within the welding parameters overview.

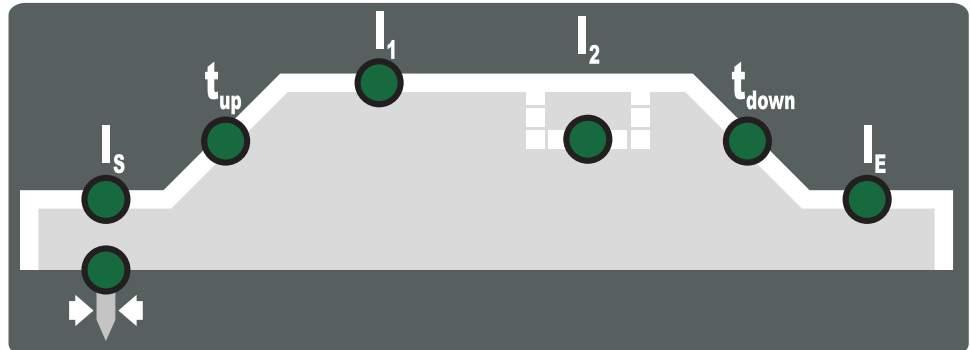

Welding parameters overview

The welding parameters overview contains the following welding parameters:



Starting current I_S
for TIG welding



Upslope t_{up}

the period of time when TIG welding over which the current is increased from the starting current I_S to the specified main current I_1

IMPORTANT! Upslope t_{up} is saved separately for 2-step and 4-step modes.



Main current I_1 (welding current)

- for TIG welding
- for MMA welding



Reduced current I_2

for TIG 4-step mode and TIG special 4-step mode



Downslope t_{down}

the period of time when TIG welding over which the current is decreased from the main current I_1 to the end current I_E

IMPORTANT! The downslope t_{down} is saved separately for 2-step and 4-step modes.



Final current I_E

for TIG welding



Electrode diameter

used in TIG welding to enter the diameter of the tungsten electrode

(12)	Adjusting dial
------	-----------------------

for altering welding parameters. If the indicator on the adjusting dial lights up, then the selected welding parameter can be altered.

Item	Designation
(13)	<p>Welding current indicator to indicate the welding current for the parameters</p> <ul style="list-style-type: none">- Starting current I_S- Welding current I_1- Reduced current I_2- End current I_E <p>Before welding commences, the left-hand digital display shows the set value. For I_S, I_2 and I_E, the right-hand digital display also shows the respective percentage of the welding current I_1.</p> <p>After the start of welding, the welding parameter I_1 is automatically selected. The left-hand digital display shows the actual welding current value.</p> <p>In the welding parameters overview (11), LEDs for the various parameters (I_S, t_{up}, etc.) light up to show the current position in the welding process.</p>
(14)	<p>Left Parameter Selection button for selecting welding parameters within the welding parameters overview (11)</p> <p>When a welding parameter is selected, the LED on the relevant parameter symbol lights up.</p>

Key combinations - special functions

General

The following functions can be executed by pressing buttons simultaneously or repeatedly.

Displaying the software version and operating time



Display software version:
while pressing and holding the Mode button, press the left Parameter Selection button.



The software version is now shown on the digital displays.



Display PC board version:
press the left Parameter Selection button again



The PC board version is now shown on the digital displays.



To exit, press the Mode button.

Connections, switches and mechanical components

Connections, switches and mechanical components

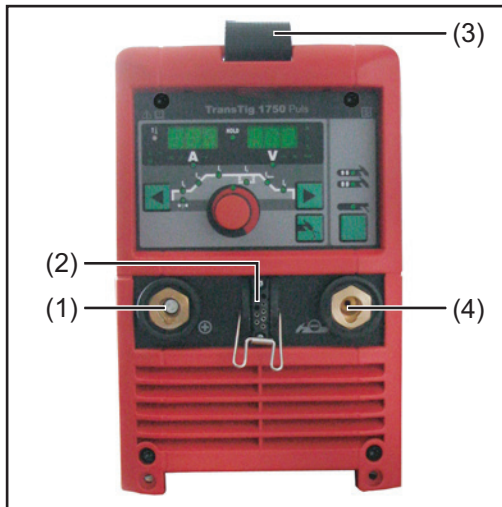

TransTig 1750 Puls - front

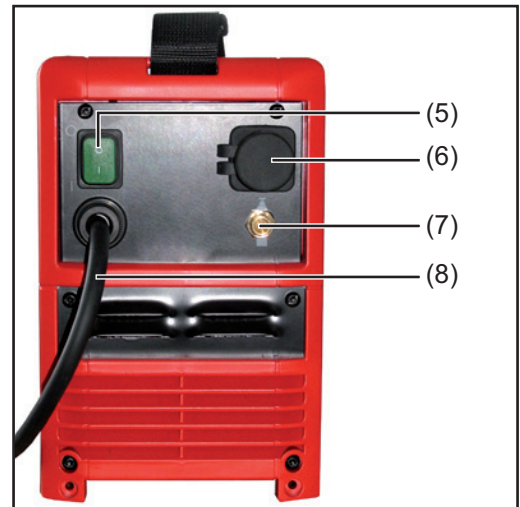

TransTig 1750 Puls - rear

Item	Designation
(1)	(+) current socket with bayonet latch for connecting <ul style="list-style-type: none"> - the grounding (earthing) cable when TIG welding - the electrode cable or grounding (earthing) cable in MMA welding (depending on electrode type)
(2)	Torch control connection for connecting the control plug of a conventional welding torch
(3)	Carrying strap
(4)	(-) current socket with bayonet latch for connecting <ul style="list-style-type: none"> - the TIG welding torch - the electrode cable or grounding (earthing) cable in MMA welding (depending on electrode type)
(5)	Mains switch for switching the power source on and off
(6)	LocalNet connection connection socket for remote control
(7)	Shielding gas connection
(8)	Mains cable with strain relief device

Installation and commissioning

Minimum equipment needed for welding task

General

Depending on which welding process you intend to use, a certain minimum equipment level will be needed in order to work with the power source. The welding processes and the minimum equipment levels required for the welding task are then described.

TIG DC welding

- Power source
 - Grounding (earthing) cable
 - TIG welding torch with rocker switch
 - Gas connection (shielding gas supply)
 - Filler metals (as required by the application)
-

MMA welding

- Power source
- Grounding (earthing) cable
- Electrode holder
- Rod electrodes (as required by the application)

Before installation and commissioning

Safety



WARNING! Operating the equipment incorrectly can cause serious injury and damage. Do not use the functions described until you have thoroughly read and understood the following documents:

- these operating instructions
- all the operating instructions for the system components, especially the safety rules

Utilisation for intended purpose

The power source is intended exclusively for TIG and MMA welding. Utilisation for any other purpose, or in any other manner, shall be deemed to be not in accordance with the intended purpose. The manufacturer shall not be liable for any damage resulting from such improper use.

Proper use also includes:

- following all the information in the operating instructions
- carrying out all the specified inspection and servicing work

Setup regulations

The device is tested to "Degree of protection IP23", meaning:

- protection against penetration by solid foreign bodies with diameters > 12.5 mm (0.49 in.)
- protection against direct sprays of water up to 60° from the vertical

The device can be set up and operated outdoors in accordance with IP23. Avoid direct wetting (e.g. from rain).



WARNING! If one of these machines topples over or falls it could cause serious or even fatal injury. Place device on a solid, level surface in such a way that it remains stable.

The venting duct is a very important safety feature. When choosing the location for the device, ensure that the cooling air can enter and exit unhindered through the air ducts on the front and back of the device. Electrically conductive dust (e.g. from grinding work) must not be allowed to get sucked into the device.

Mains connection

The devices are designed to run on the mains voltage shown on the respective rating plates. If your version of the device does not come with mains cables and plugs ready-fitted, these must be fitted in accordance with national regulations and standards. For details of fuse protection of the mains lead, please see the Technical Data.



NOTE! Inadequately dimensioned electrical installations can cause serious damage. The incoming mains lead and its fuse must be dimensioned to suit the local power supply. The technical data shown on the rating plate applies.

Generator-powered operation

The power source is generator-compatible, provided that the maximum apparent power delivered by the generator is at least 10 kVA.



NOTE! The voltage delivered by the generator must never exceed the upper or lower limits of the mains voltage tolerance range. Details of the mains voltage tolerance are given in the "Technical data" section.

Start-up

Safety



WARNING! An electric shock can be fatal. If the machine is plugged into the mains electricity supply during installation, there is a high risk of very serious injury and damage. Do not carry out any work on the device unless

- the mains switch is in the "O" position,
- the device is unplugged from the mains.

General

Commissioning of the power source is described using a standard configuration for the main TIG welding application.

The standard configuration consists of the following system components:

- Power source
- TIG manual welding torch
- Pressure regulator
- Gas cylinder

Connecting the gas cylinder



WARNING! If gas cylinders topple over, there is a risk of very serious injury and damage.

- Place gas cylinders on a solid, level surface in such a way that they remain stable
- Secure gas cylinders to prevent them from toppling over: fix the safety strap at the same height as the top part of the cylinder
- Never fix the safety strap around the neck of the cylinder

Follow the gas cylinder manufacturer's safety instructions.

- 1 Secure the gas cylinder
- 2 Take the protective cap off the gas cylinder
- 3 Briefly open the gas cylinder valve to remove any dust or dirt
- 4 Check the seal on the pressure regulator
- 5 Screw the pressure regulator onto the gas cylinder and tighten it

When using a TIG welding torch with an integral gas connector:

- 6 Use the gas hose to connect the pressure regulator to the shielding gas connection on the rear of the power source
- 7 Tighten the union nut on the gas hose

When using a TIG welding torch with no integral gas connector:

- 6 Connect the TIG welding torch gas hose to the pressure regulator

Establishing a ground (earth) connection to the workpiece

- 1 Move the mains switch to the "O" position
- 2 Plug the grounding (earthing) cable into the (+) current socket and latch it in place
- 3 Use the other end of the grounding (earthing) cable to establish a connection to the workpiece

Connecting the welding torch

- 1 Move the mains switch to the "O" position
- 2 Plug the welding cable of the TIG torch into the (-) current socket and twist it clockwise to latch it in place
- 3 Plug the control plug of the welding torch into the torch control connection and latch it in place



NOTE! Do not use pure tungsten electrodes (colour-coded green).

- 4 Fit the welding torch in accordance with the welding torch operating instructions

Welding

TIG modes

Safety



WARNING! Operating the equipment incorrectly can cause serious injury and damage. Do not use the functions described until you have thoroughly read and understood the following documents:

- these operating instructions
- all the operating instructions for the system components, especially the safety rules

See the "The Setup menu" section for information on the settings, setting range and units of measurement of the available welding parameters.

Symbols and their explanations

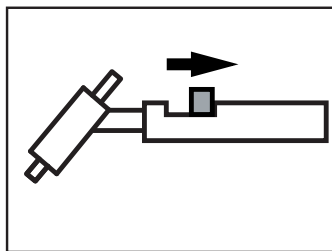

Pull back and hold the torch trigger

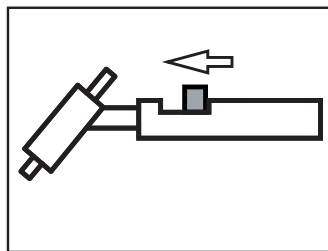

Release the torch trigger

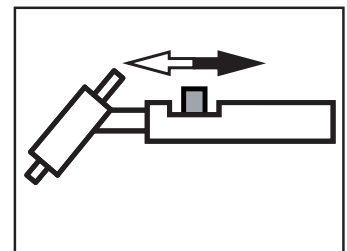

Briefly pull back the torch trigger (< 0.5 s)

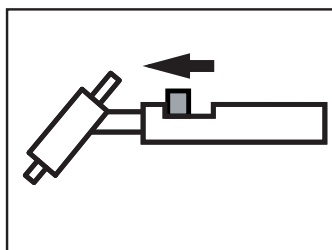

Push forward and hold the torch trigger

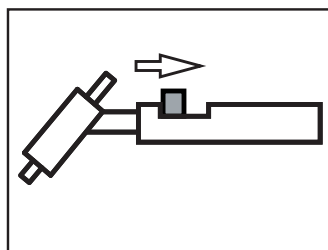

Release the torch trigger

GPr

Gas pre-flow time

I_s

Starting current phase: the temperature is raised gently, at low welding current, so that the filler metal can be positioned correctly

t_s

Starting current time

t_{up}

Upslope phase: the starting current is continuously increased until it reaches the main current (welding current) I₁

I₁

Main current phase (welding current phase): uniform thermal input into the base material, whose temperature is raised by the advancing heat

I₂

Reduced current phase: intermediate lowering of the welding current in order to prevent any local overheating of the base material

t_{down}
Downslope phase: the welding current is continuously lowered until it reaches the end-crater current

I_E
End current phase: to prevent any local overheating of the base material due to heat build-ups towards the end of welding. This eliminates any risk of weld drop-through.

t_E
End current time

SPT
Spot welding time

G-H
Gas post-flow time at maximum welding current

G-L
Gas post-flow time at minimum welding current

2-step mode

- Welding: pull back and hold the torch trigger
- End of welding: release the torch trigger

IMPORTANT! To work in 2-step mode after 2-step mode has been selected, the SPT setup parameter must be set to "OFF" and the special spot welding indicator on the control panel must not light up.

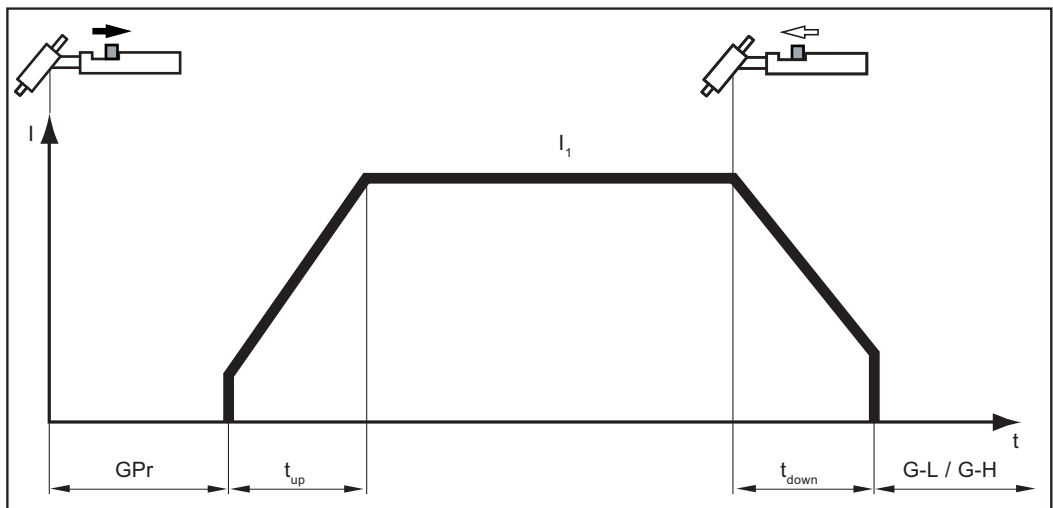

Spot welding

If a value has been set for the SPT setup parameter, 2-step mode will have the function of spot welding mode. The special spot welding indicator on the control panel lights up.

- Welding: briefly pull back the torch trigger
The welding time corresponds to the value set for the SPT setup parameter.
- To end the welding process prematurely: pull the torch trigger back again

When using a pedal remote control unit, the spot welding time starts when the pedal remote control is operated. The power cannot be controlled using the pedal remote control unit.

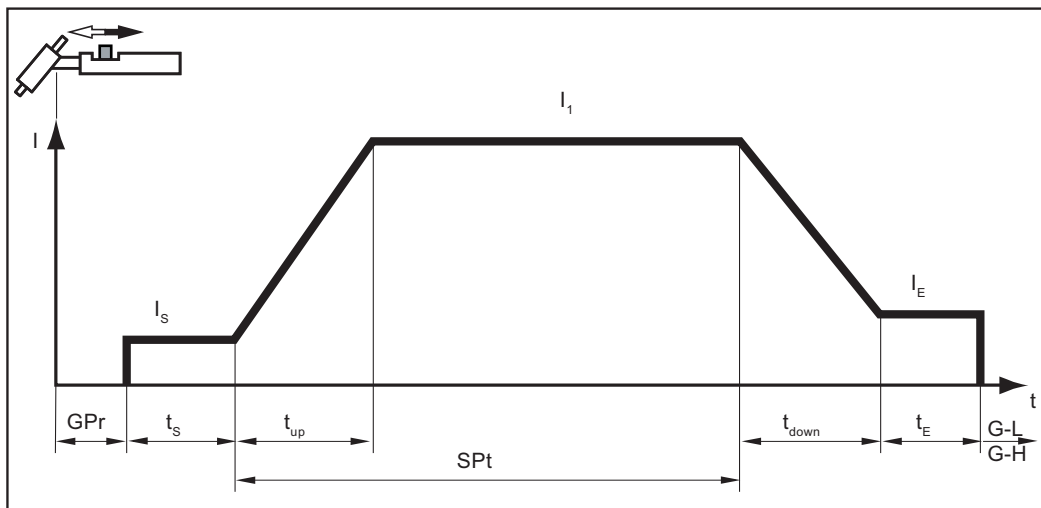

4-step mode

- Welding start-up with starting current I_s : pull back and hold the torch trigger
- Welding with main current I_1 : release the torch trigger
- Lowering to end current I_E : pull back and hold the torch trigger
- End of welding: release the torch trigger

IMPORTANT! For 4-step mode, the SFS setup parameter must be set to "OFF".

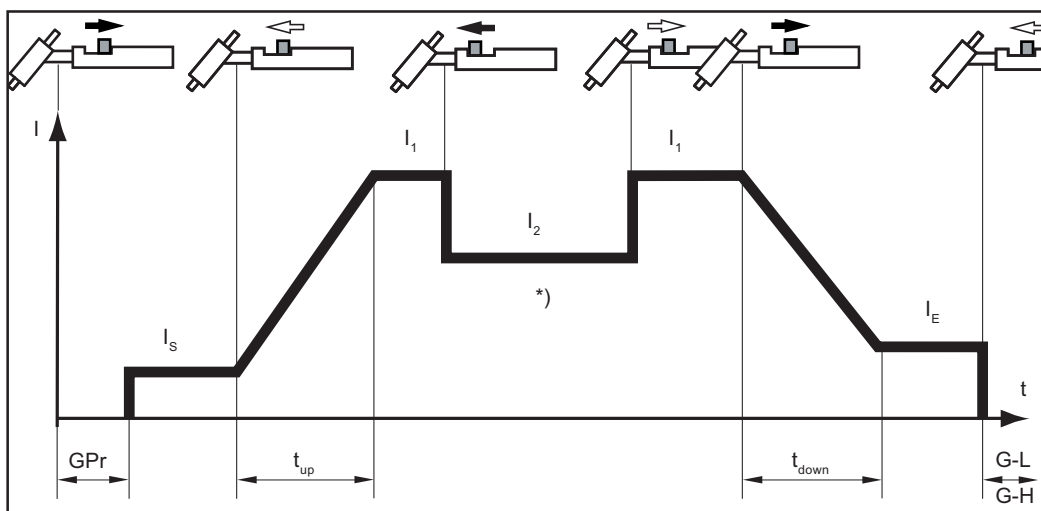

*) Intermediate lowering

Intermediate lowering during the main current phase causes the welding current to be reduced to the specified reduced current I_2 .

- To activate intermediate lowering, push forward and hold the torch trigger
- To revert to the main current, release the torch trigger

**Special 4-step:
variant 1**

Variant 1 of the special 4-step mode is activated when the SFS setup parameter is set to "1".

Briefly pull back the torch trigger to start intermediate lowering to the specified reduced current I_2 . When the torch trigger is briefly pulled back a second time, the main current I_1 is restored.

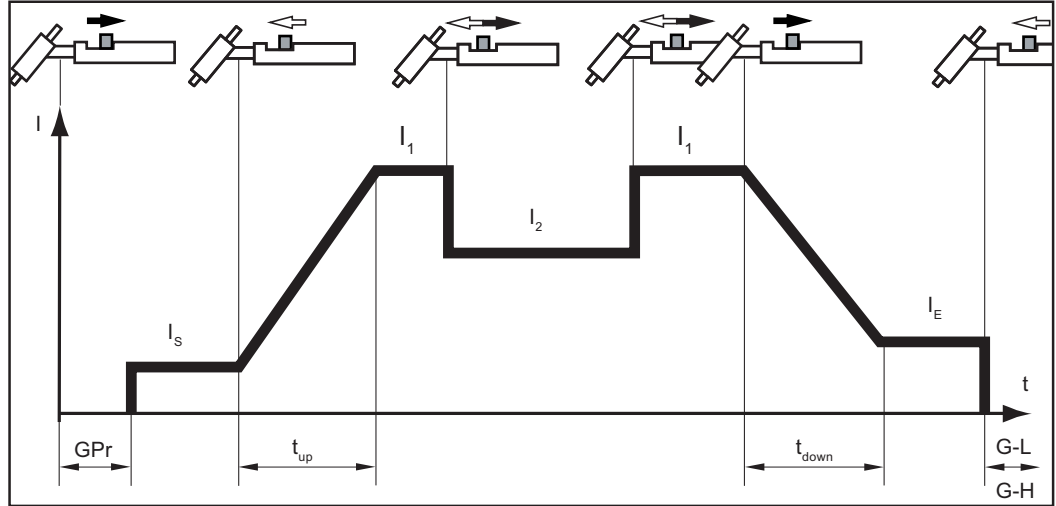

Overloading of the tungsten electrode

Overloading of the tungsten electrode



If the tungsten electrode is overloaded, the "Electrode overload" indicator on the control panel lights up.

Possible causes of tungsten electrode overload:

- tungsten electrode diameter is too small
- main current value I_1 set too high

Remedy:

- use a tungsten electrode with a larger diameter
- reduce the main current

IMPORTANT! The "Electrode overload" indicator is designed to work with ceriated electrodes. For all other electrodes, the "Electrode overload" indicator must be treated as a reference value.

TIG welding

Safety



WARNING! Operating the equipment incorrectly can cause serious injury and damage. Do not use the functions described until you have thoroughly read and understood the following documents:

- these operating instructions
- all the operating instructions for the system components, especially the safety rules



WARNING! An electric shock can be fatal. If the power source is connected to the mains electricity supply during installation, there is a high risk of very serious injury and damage. Before carrying out any work on the device make sure that:

- the power source mains switch is in the "O" position
- the power source is unplugged from the mains

Welding parameters



Starting current I_s

Unit	%
Setting range	0 - 200 % of main current I_1
Factory settings	50



Upslope t_{up}

Unit	s
Setting range	0.01 - 9.9
Factory settings	0.5

IMPORTANT! The upslope t_{up} is saved separately for 2-step and 4-step modes.



Main current I_1

Unit	A
Setting range	2 - 170
Factory settings	2

IMPORTANT! On welding torches with the Up/Down function, the entire setting range can be selected while the device is idling. During welding, the main current can be corrected in steps of +/-20 A.



Reduced current I_2 (4-step mode)

Unit	% (of main current I_1)
Setting range	0 - 100
Factory settings	50



Downslope t_{down}

Unit	s
Setting range	0.01 - 9.9
Factory settings	1.0

IMPORTANT! The downslope t_{down} is saved separately for 2-step and 4-step modes.

 End current I_E	
Unit	% (of main current I_1)
Setting range	0 - 100
Factory settings	30

 Electrode diameter	
Unit	mm
Setting range	OFF / 0.1 - 3.2
Factory settings	2.4

Preparations

- 1 Plug in the mains plug



CAUTION! Risk of injury and damage from electric shock. As soon as the mains switch is in the "I" position, the tungsten electrode of the welding torch is LIVE. Make sure that the tungsten electrode does not touch any persons or electrically conductive or earthed parts (e.g. housing, etc.).

- 2 Turn the mains switch to the "I" position

All the indicators on the control panel light up briefly.

TIG welding

- 1 Press the Mode button to select the required TIG mode:



2-step mode



4-step mode

- 2 Use the left or right Parameter Selection button to select the relevant parameters in the welding parameters overview
- 3 Use the adjusting dial to set the selected welding parameters to the desired value

All parameter set values that were set using the adjusting dial will remain stored until they are changed. This applies even if the power source is switched off and on again in the meantime.

- 4 Open the gas cylinder valve
- 5 Set the shielding gas flow rate:
 - Press the Gas test button
The test gas flow lasts for a maximum of 30 seconds. Press the button again to stop the gas flow prematurely.
 - Turn the adjusting screw on the underside of the pressure regulator until the pressure gauge shows the desired gas flow rate.
- 6 For longer hosepacks and if condensation forms when the device is left unused in a cold environment:
purge shielding gas and set the GPU setup parameter to a time value
- 7 Start welding (ignite the arc)

Igniting the arc

Igniting the arc using high frequency (HF ignition)

HF ignition is activated when a time value has been set for the HFt setup parameter. The HF ignition indicator lights up on the control panel.

HF

Compared with touchdown ignition, HF ignition eliminates the risk of contamination of the tungsten electrode and the workpiece.

Procedure for HF ignition:

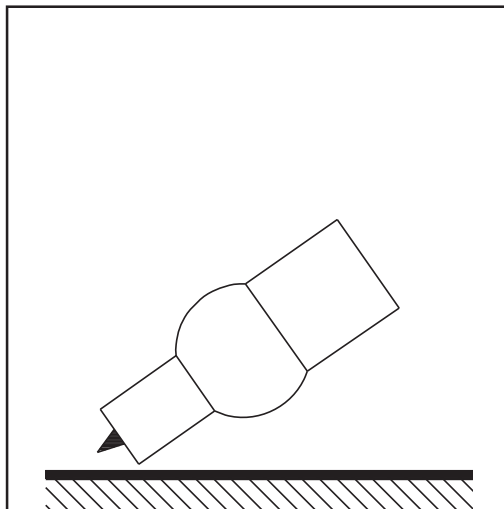

- 1 Place the gas nozzle down on the ignition location so that there is a gap of approx. 2 to 3 mm (5/64 to 1/8 in.) between the tungsten electrode and the workpiece

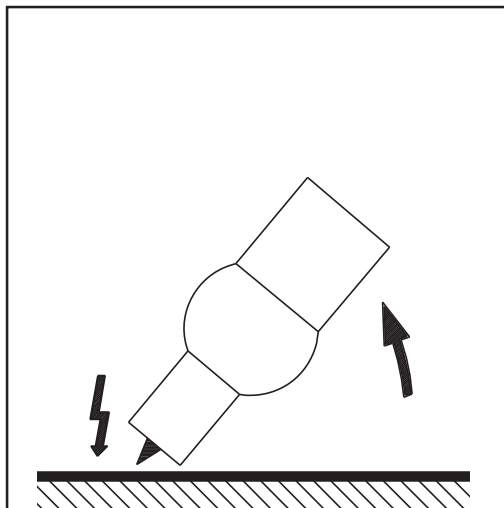

- 2 Increase the tilt angle of the torch and actuate the torch trigger according to the mode you have selected

The arc ignites without the electrode touching down on the workpiece.

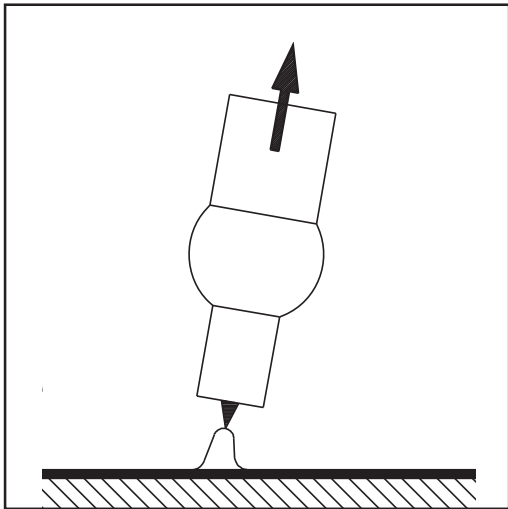

- 3 Tilt the torch back into the normal position
- 4 Carry out welding

Touchdown ignition

If the HFt setup parameter is set to OFF, HF ignition is deactivated. The welding arc is ignited by touching the workpiece with the tungsten electrode.

Procedure for igniting the arc using touchdown ignition:

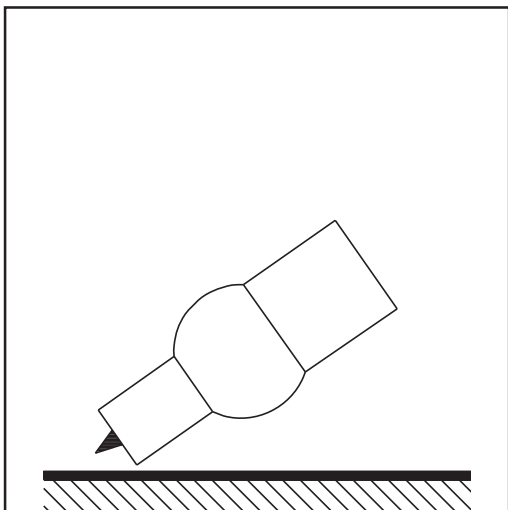

- 1 Place the gas nozzle down on the ignition location so that there is a gap of approx. 2 to 3 mm (5/64 to 1/8 in.) between the tungsten electrode and the workpiece

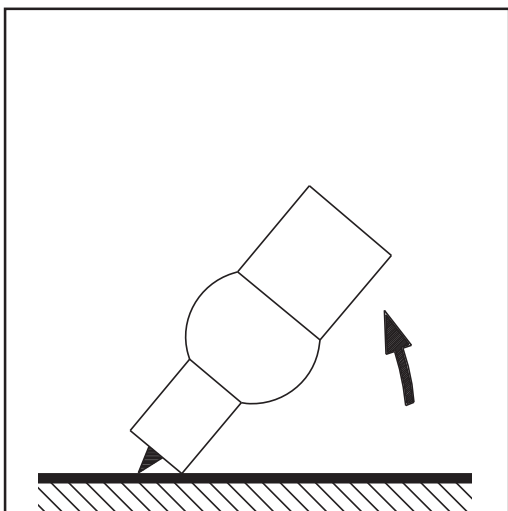

- 2 Actuate the torch trigger
Shielding gas flows.
- 3 Gradually tilt the welding torch up until the tungsten electrode touches the workpiece

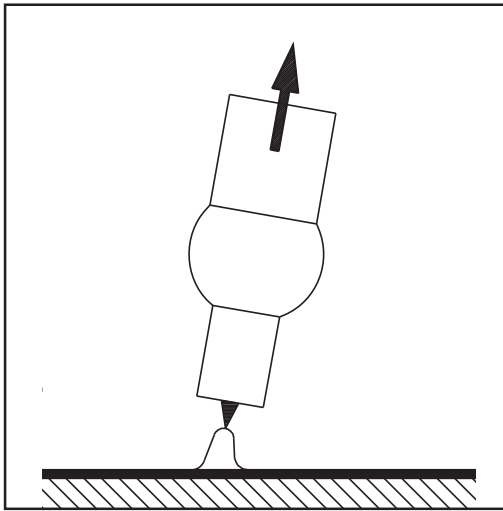

- 4 Raise the welding torch and move it into its normal position

The arc ignites.

- 5 Carry out welding

End of welding

- 1 Depending on the set mode, finish welding by releasing the torch trigger
- 2 Wait for the set gas post-flow and hold welding torch in position over the end of the weld seam

Special functions and options

Arc break watchdog function

If the arc breaks and no current starts to flow again within a time specified in the Setup menu, the power source cuts out automatically. The service code "no | Arc" appears on the control panel.

To start the welding process again, press any key on the control panel or the torch trigger.

The settings for the arc break watchdog setup parameter are described in the "Setup menu: level 2" section.

Ignition time-out function

The power source has the Ignition time-out function.

Once the torch trigger is pressed, gas pre-flow begins immediately. Ignition then begins. If no arc appears within the time specified in the Setup menu, the power source cuts out automatically. The service code "no | IGn" appears on the control panel.

To try again, press any key on the control panel or press the torch trigger.

The settings for the Ignition time-out parameter (ito) are described in the "Setup menu: level 2" section.

TIG pulsing

The welding current set at the start of welding is not always ideal for the welding process as a whole:

- if the current is too low, the base material will not melt sufficiently,
- if overheating occurs, the liquid weld pool may drip.

The TIG pulsing function (TIG welding with pulsing welding current) offers a remedy: a low ground current I-G rises steeply to the significantly higher pulse current I1 and, depending on the set dcY (duty cycle) time, drops back to the ground current I-G. In TIG pulsing, small sections of the welding location melt quickly and then solidify again quickly.

In manual applications using TIG pulsing, the filler wire is applied in the maximum current phase (only possible in the low frequency range: 0.25 - 5 Hz). Higher pulse frequencies are mainly used in automatic mode to stabilise the arc.

TIG pulsing is used for out-of-position welding of steel pipes or when welding thin sheets.

How TIG pulsing works:

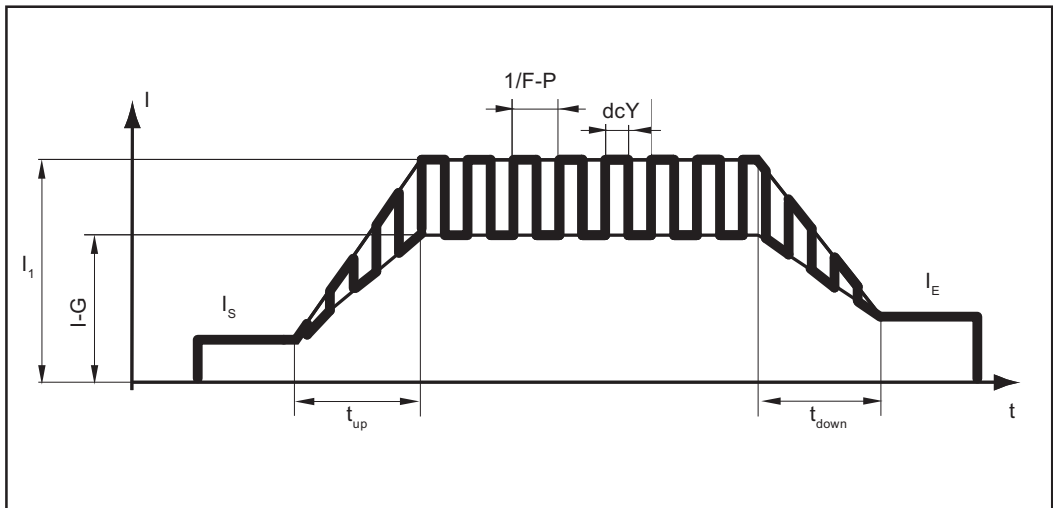

TIG pulsing - welding current curve

Legend:

I_s	Starting current	$F-P$	Pulse frequency *)
I_E	End current	dcY	Duty cycle
t_{up}	Upslope	$I-G$	Ground current
t_{Down}	Downslope	I_1	Main current

*) ($1/F-P$ = time interval between two pulses)

Tacking function The power source has a tacking function.

When a time period is specified for the tAC (tacking) setup parameter, the tacking function is assigned to the 2-step mode and 4-step mode. The operating sequence of the modes remains unchanged.

During this period, a pulsed welding current is present that makes the weld pool run together better when two parts are being tacked.

How the tacking function works:

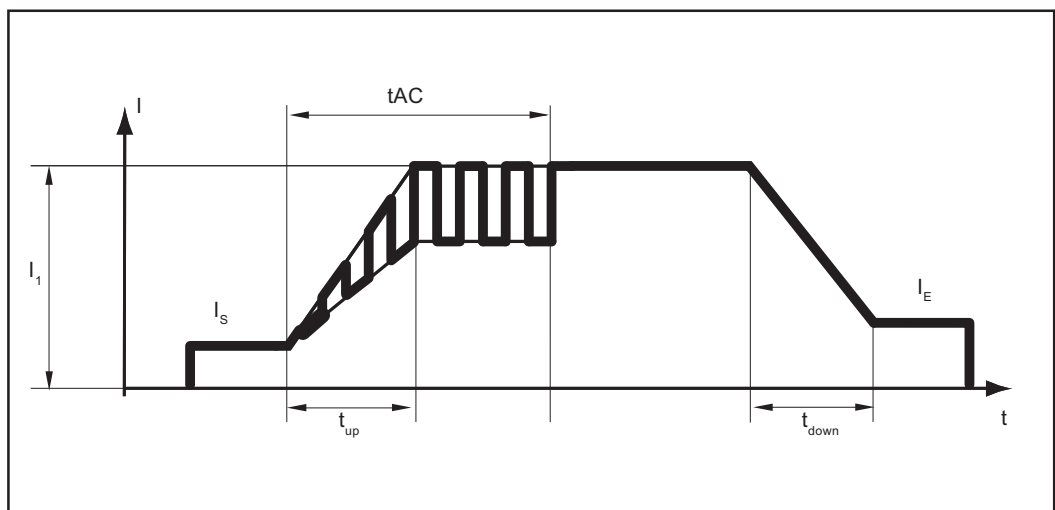

Tacking function - welding current curve

Legend:

tAC	Duration of pulsed welding current for the tacking process
-------	--

I_S	Starting current
I_E	End current
t_{up}	Upslope
t_{Down}	Downslope
I_1	Main current

IMPORTANT! The following points apply to the pulsed welding current:

- The power source automatically regulates the pulsing parameters as a function of the specified main current I_1
- There is no need to set any pulsing parameters

The pulsed welding current begins:

- After the end of the starting current phase I_S
- With the upslope phase t_{up}

Depending on what tAC time has been set, the pulsed welding current may continue up to and including the end current phase I_E (tAC setup parameter set to "ON").

After the tAC time has elapsed, welding continues at a constant welding current, and any pulsing parameters that may have been set continue to be available.

IMPORTANT! To set a specified tacking time, the tAC setup parameter can be combined with the SPt setup parameter (spot welding time).

MMA welding

Safety



WARNING! Operating the equipment incorrectly can cause serious injury and damage. Do not use the functions described until you have thoroughly read and understood the following documents:

- these operating instructions
- all the operating instructions for the system components, especially the safety rules



WARNING! An electric shock can be fatal. If the power source is connected to the mains electricity supply during installation, there is a high risk of very serious injury and damage. Before carrying out any work on the device make sure that:

- the power source mains switch is in the "O" position
- the power source is unplugged from the mains

Preparations

- 1 Move the mains switch to the "O" position
- 2 Unplug the device from the mains
- 3 Disconnect the TIG welding torch
- 4 Plug the grounding (earthing) cable in and latch it into place:
 - for rod electrode DC- welding in the (+) - current socket
 - for rod electrode DC+ welding in the (-) current socket
- 5 Use the other end of the earthing (grounding) cable to establish a connection to the workpiece
- 6 Plug in the electrode cable and twist it clockwise to latch it into place:
 - for rod electrode DC- welding in the (-) current socket
 - for rod electrode DC+ welding in the (+) - current socket
- 7 Plug in the mains plug



CAUTION! Risk of injury and damage from electric shock. As soon as the mains switch is in the "I" position, the rod electrode in the electrode holder is LIVE. Make sure that the rod electrode does not touch any persons or electrically conducting or earthed parts (e.g. the housing etc.).

- 8 Turn the mains switch to the "I" position

All the indicators on the control panel light up briefly.

MMA welding

- 1 Press the Mode button to select:



MMA welding mode

IMPORTANT! If the MMA welding mode is selected, the welding voltage will only be available after a 3-second time lag.

- 2 Use the adjusting dial to set the desired welding current.

The welding current value is shown in the left-hand digital display.

All the parameter set values that have been set using the adjusting dial are saved until

the next time they are changed. This applies even if the power source is switched off and on again in the meantime.

3 Start welding

HotStart function To obtain optimum welding results, it will sometimes be necessary to adjust the HotStart function.

Benefits

- Improved ignition, even when using electrodes with poor ignition properties
- Better fusion of the base material in the start-up phase, meaning fewer cold-shut defects
- Largely prevents slag inclusions

See the "Setup menu: level 2" section for details on setting the available welding parameters.

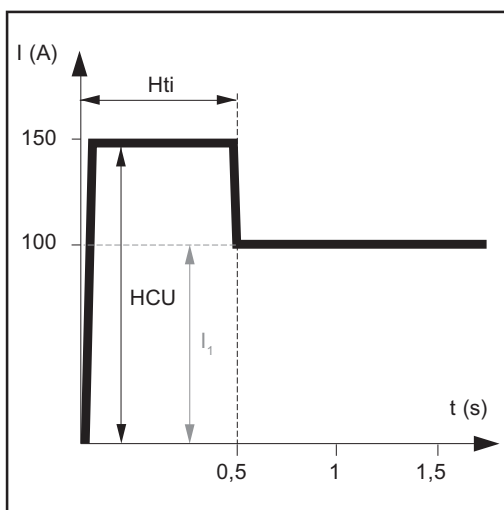

Example of HotStart function

Legend

- Hti Hot-current time, 0-2 s, factory setting: 0.5 s
- HCU HotStart current, 0-200 %, factory setting 150 %
- I_1 Main current = set welding current

Function:

during the specified hot-current time (Hti), the welding current I_1 is increased to the Hotstart current HCU.

To activate the HotStart function, the Hot-start current HCU must be > 100.

Setting examples:

HCU = 100

The HotStart current is adequate to the actually set welding current I_1 .
The HotStart function is not activated.

HCU = 170

The HotStart current is 70 % higher than the actually set welding current I_1 .
The HotStart function is activated.

HCU = 200

The HotStart current is adequate twice the actually set welding current I_1 .
The HotStart function is activated, the HotStart current is at its maximum.
 $HCU = 2 \times I_1$

Anti-stick function

As the arc becomes shorter, the welding voltage may drop so far that the rod electrode will tend to stick. This may also cause the rod electrode to burn out.

Electrode burn-out is prevented by activating the anti-stick function. If the rod electrode begins to stick, the power source immediately switches the welding current off. After the rod electrode has been detached from the workpiece, the welding process can be continued without any problems.

The anti-stick function can be activated and deactivated in the "Setup menu: level 2" section.

Setup settings

The Setup menu

General

The Setup menu provides easy access to expert knowledge in the power source and to additional functions. The Setup menu can be used to make simple adjustments of the welding parameters to suit the various job settings.

The following can be found in the Setup menu:

- Setup parameters that have an immediate effect on the welding process
- Setup parameters needed for making the preliminary settings on the welding system

The welding parameters are arranged in logical groups. Each of these groups is called up by pressing a different combination of buttons.

Overview

"The Setup menu" is composed of the following sections:

- Shielding gas setup menu
- TIG setup menu
- TIG setup menu: level 2
- Rod electrode setup menu
- Rod electrode setup menu: level 2

Shielding gas setup menu

General

The Shielding gas setup menu provides easy access to the shielding gas settings.

Accessing the Shielding gas setup menu



1 Press and hold the Mode button



2 Press the Gas test button

The power source is now in the Shielding gas setup menu. The last welding parameter selected is displayed.

Changing weld- ing parameters



1 Use the left or right Parameter Selection button to select the parameter that you want to change



2 Use the adjusting dial to change the parameter value

Exiting the Shielding gas setup menu



1 Press the Mode button

Welding parameters in the Shielding gas setup menu

GPr

Gas pre-flow time

Unit	s
Setting range	0.0 - 9.9
Factory settings	0.4

G-L

Gas low - gas post-flow time at minimum welding current (minimum gas post-flow time)

Unit	s
Setting range	0.0 - 25.0
Factory settings	5

G-H

Gas high - increase in the gas post-flow time at maximum welding current

Unit	s
Setting range	0.0 - 40.0 / Aut
Factory settings	Aut

The value set for G-H only applies if the maximum welding current really has been set. The actual value is derived from the present welding current. For a medium welding current, for example, the actual value will be half of the value set for G-H.

IMPORTANT! The values set for the G-L and G-H setup parameters are added together. For example, if both parameters are set to the maximum (40 s), the gas post-flow will last:

- 40 s at minimum welding current
- 80 s at maximum welding current
- 60 s if the welding current is exactly half the maximum, etc.

If Aut is set, the gas post-flow time G-H is calculated automatically.

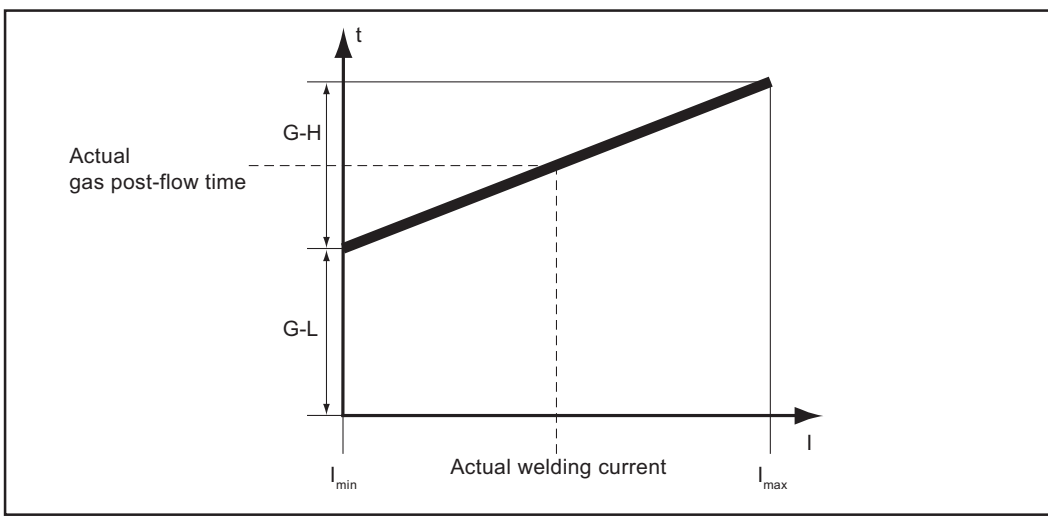

Gas post-flow time as a function of the welding current

GPU

Gas purger - purging of shielding gas

Unit	min
Setting range	OFF / 0.1 - 10.0
Factory settings	OFF

Purging of the shielding gas begins as soon as GPU is allocated a value.

For safety reasons, purging of the shielding gas cannot be restarted until a new GPU value is entered.

IMPORTANT! Purging of the shielding gas is necessary if condensation forms when the device is left unused in a cold environment for a prolonged period. Long hosepacks are most affected.

TIG setup menu

Accessing the TIG setup menu



1 Press the Mode button to select 2-step mode or 4-step mode

2 Press and hold the Mode button

3 Press the Parameter Selection button (right)

The power source is now in the TIG setup menu. The last welding parameter selected is displayed.

Changing welding parameters

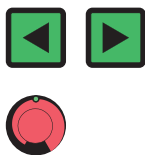

1 Use the left or right Parameter Selection button to select the parameter that you want to change

2 Use the adjusting dial to change the parameter value

Exiting the TIG setup menu



1 Press the Mode button

Welding parameters in the TIG setup menu

SPT

Spot welding time

Unit s

Setting range OFF / 0.05 - 25.0

Factory settings OFF

If a value has been set for the SPT setup parameter, the operating mode 2-step mode will have the function of the spot welding mode.

The special spot welding indicator on the control panel remains lit as long as a value has been specified for the spot welding time.



tAC

Tacking function when TIG DC welding is selected: Duration of the pulsed welding current at the start of tacking

Unit s

Setting range OFF / 0.1 - 9.9 / ON

Factory settings	OFF
"ON"	The pulsed welding current continues until the end of the tacking operation
0.1 - 9.9 s	The set time begins with the upslope phase. After the end of the set time, welding continues at a constant current; any pulsing parameters that have been set are available.
"OFF"	The tacking function is switched off

The special tacking indicator on the control panel remains lit as long as a value has been specified for the tacking time.



F-P

Frequency pulsing

Unit	Hz / kHz.
Setting range	OFF / 0.20 Hz - 2.00 kHz
Factory settings	OFF

The set pulse frequency is also used for the reduced current I2.

IMPORTANT! If F-P is set to "OFF", the dcY and I-G setup parameters cannot be selected.

The special pulsing indicator on the control panel remains lit as long as a value has been specified for the pulse frequency.



Selecting the pulse frequency F-P:

0.2 Hz to 5 Hz	Thermal pulsing (out-of-position welding, automated welding)
1 kHz to 2 kHz	Arc-stabilising pulsing (stabilising the arc at a low welding current)

dcY

Duty cycle - the ratio of pulse duration to the ground current duration when a pulse frequency has been set

Unit	%
Setting range	10 - 90
Factory settings	50

I-G

I (current) - ground current

Unit	% (of main current I1)
Setting range	0 - 100
Factory settings	50

t-S

Time starting - starting current time

Unit	s
Setting range	OFF/0.01 - 9.9
Factory settings	OFF

The starting current time t-S specifies the duration of the starting current phase I_s.

IMPORTANT! The t-S setup parameter only applies to 2-step mode. In 4-step mode, the duration of the starting current phase I_s is controlled using the torch trigger.

t-E

Time end - end current time

Unit	s
Setting range	OFF/0.01 - 9.9
Factory settings	OFF

The end current time t-E specifies the duration of the end current phase I_E.

IMPORTANT! The setup parameter t-E only applies to 2-step mode. In 4-step mode, the duration of the end current phase I_E is controlled using the torch trigger (see "TIG operating modes").

FAC

Factory - for resetting the welding system

Press and hold the Mode button for 2 s to reset the system to the factory settings. When the digital display shows "PrG", the welding system has been reset.

IMPORTANT! When the welding system is reset, all the personal settings in the Setup menu are lost. Welding parameter settings in Setup menu: level 2 are not deleted.

2nd

Setup menu: level 2: second level of the setup menu

TIG setup menu: level 2

Accessing the TIG setup menu: level 2



- 1 Accessing the TIG setup menu
- 2 Select "2nd" welding parameter
- 3 Press and hold the Mode button

- 4 Press the Parameter Selection button (right)

The power source is now in TIG set-up menu - level 2. The last welding parameter selected is displayed.

Changing welding parameters



- 1 Use the left or right Parameter Selection button to select the parameter that you want to change

- 2 Use the adjusting dial to change the parameter value

Exiting the TIG setup menu: level 2



- 1 Press the Mode button

The power source is now in the TIG setup menu.

- 2 To exit the TIG setup menu, press the Mode button again

Welding parameters in the TIG setup menu: level 2

SFS

Special 4-step mode

Unit -

Setting range OFF/1

Factory settings OFF

HFt

High frequency time: time interval between the HF pulses

Unit s

Setting range 0.01 - 0.4 / OFF

Factory settings 0.01



NOTE! If there are problems with sensitive equipment in the immediate vicinity, increase the HFt parameter to a maximum of 0.4 s.

The special HF ignition indicator remains lit as long as a value has been specified for the HFt parameter.



If the HFt setup parameter is set to "OFF", no high-frequency ignition takes place at the start of welding. In this case, the start of welding commences with touchdown ignition.

Ito

Ignition time-out - time until the safety cut-out is triggered following an abortive ignition attempt

Unit	s
Setting range	0.1 - 9.9
Factory settings	5

IMPORTANT! Ignition time-out is a safety function and cannot be deactivated. The description of the ignition time-out function can be found in "TIG welding".

Arc

Arc - arc break watchdog: time until the safety cut-out is triggered following an arc break

Unit	s
Setting range	0.1 - 9.9
Factory settings	2

IMPORTANT! The arc break watchdog is a safety function and cannot be deactivated. The description of the arc break watchdog function can be found in "TIG welding".

ACS

Automatic current switch - automatic switchover to main current

Unit	-
Setting range	ON / OFF
Factory settings	ON

ON The parameter I1 (main current) will automatically be selected after welding has started. The main current I1 can be set immediately.

OFF The last selected parameter remains set during welding. The last selected parameter can be set immediately. Parameter I1 is not selected automatically.

Rod electrode setup menu

Accessing the Rod electrode setup menu



- 1 Press the Mode button to select the MMA welding mode
- 2 Press and hold the Mode button
- 3 Press the Parameter Selection button (right)

The power source is now in the Rod electrode setup menu. The last welding parameter selected is displayed.

Changing welding parameters

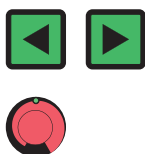

- 1 Use the left or right Parameter Selection button to select the parameter that you want to change
- 2 Use the adjusting dial to change the parameter value

Exiting the Rod electrode setup menu



- 1 Press the Mode button

Welding parameters in the Rod electrode setup menu

HCU

HotStart current

Unit %

Setting range 0 - 200

Factory settings 150

Hti

Hot-current time

Unit s

Setting range 0.0 - 2.0

Factory settings 0.5

To obtain optimum welding results, it will sometimes be necessary to adjust the HotStart function.

Benefits

- Improved ignition, even when using electrodes with poor ignition properties
- Better fusion of the base material in the start-up phase, meaning fewer cold-shut defects
- Largely prevents slag inclusions

dyn

dYn - dynamic correction

Unit	-
Setting range	0 - 100
Factory settings	20
0	soft, low-spatter arc
100	harder, more stable arc

To obtain optimum welding results, it will sometimes be necessary to adjust the arc-force dynamic.

Functional principle:

at the instant of droplet transfer or when a short circuit occurs, there is a momentary rise in amperage. In order to obtain a stable arc, the welding current is temporarily increased. If the rod electrode threatens to sink into the weld pool, this measure prevents the weld pool solidifying, as well as preventing more prolonged short circuiting of the arc. This largely prevents the rod electrode from sticking.

FAC

Factory - for resetting the welding system

Press and hold the Mode button for 2 s to reset the system to the factory settings. When the digital display shows "PrG", the welding system has been reset.

IMPORTANT! When the welding system is reset, all the personal settings in the Setup menu are lost. Welding parameter settings in Setup menu: level 2 are not deleted.

2ndSetup menu: level 2: second level of the setup menu

Rod electrode setup menu: level 2

Accessing the Rod electrode setup menu level 2



- 1 Accessing the Rod electrode setup menu
- 2 Select "2nd" welding parameter
- 3 Press and hold the Mode button
- 4 Press the Parameter Selection button (right)

The power source is now in the Rod electrode setup menu: level 2. The last parameter selected is displayed.

Changing welding parameters



- 1 Use the left or right Parameter Selection button to select the parameter that you want to change
- 2 Use the adjusting dial to change the parameter value

Exiting the Rod electrode setup menu: level 2



- 1 Press the Mode button
The power source is now in the Rod electrode setup menu.
- 2 To exit from the Rod electrode setup menu, press the Mode button again

Welding parameters in the Rod electrode setup menu level 2

ASt	
Anti-stick	
Unit	-
Setting range	ON / OFF
Factory settings	ON

As the arc becomes shorter, the welding voltage may drop so far that the rod electrode will tend to stick. This may also cause the rod electrode to burn out.

Electrode burn-out is prevented by activating the anti-stick function. If the rod electrode begins to stick, the power source immediately switches the welding current off. After the rod electrode has been detached from the workpiece, the welding process can be continued without any problems.

Uco	
U (voltage) cut-off - welding voltage limitation	

Unit	V
Setting range	OFF/5 - 90
Factory settings	OFF

The arc length depends on the welding voltage. To end the welding process, it is usually necessary to significantly lift the rod electrode away from the workpiece. With the "Uco" parameter, the welding voltage can be limited to a value that makes it possible to end the welding process simply by lifting the rod electrode slightly.

IMPORTANT! If the welding process often ends unintentionally during welding, set the Uco parameter to a higher value.

Troubleshooting and maintenance

Troubleshooting

General

The power source is fitted with an intelligent safety system that allows fuses to be dispensed with entirely. After a possible malfunction or error has been remedied, the power source can be put back into normal operation again without any fuses having to be replaced.

Safety



WARNING! An electric shock can be fatal. Before opening the device:

- Move the mains switch to the "O" position
- Unplug the device from the mains
- Put up an easy-to-understand warning sign to stop anybody inadvertently switching it back on again
- Using a suitable measuring device, check that electrically charged parts (e.g. capacitors) have been discharged



CAUTION! Inadequate PE conductor connections can cause serious injury and damage. The housing screws provide a suitable PE conductor connection for earthing (grounding) the housing and must NOT be replaced by any other screws which do not provide a reliable PE conductor connection.

Displayed service codes

If any error message that is not described here appears on the displays, then the fault can only be fixed by a service technician. Make a note of the error message shown in the display and of the serial number and configuration of the power source, and contact our After-Sales Service team with a detailed description of the error.

tS1 | xxx

Cause: Overtemperature in the secondary circuit of the power source (xxx stands for a temperature value)

Remedy: Allow power source to cool down

Err | tS1

Cause: temperature sensor faulty (short circuit or break)

Remedy: Contact After-Sales Service

no | IGn

Cause: Ignition time-out function is active: there was no current before the end of the time specified in the Setup menu. The safety cut-out of the power source has been triggered.

Remedy: Press the torch trigger repeatedly; clean the workpiece surface; if necessary, increase the time until the safety cut-out is triggered in Setup menu: level 2.

no | Arc

Cause: Arc break

Remedy: Press the torch trigger repeatedly; clean the surface of the workpiece

Err | IP

Cause:	Primary overcurrent
Remedy:	Contact After-Sales Service

Power source

Power source has no function

Mains switch is on, but indicators are not lit up

Cause:	There is a break in the mains lead; the mains plug is not plugged in
--------	--

Remedy:	Check the mains supply lead, make sure that the mains plug is plugged in
---------	--

Cause:	Mains socket or mains plug faulty
--------	-----------------------------------

Remedy:	Replace faulty components
---------	---------------------------

Cause:	Mains fuse is faulty
--------	----------------------

Remedy:	Change the mains fuse
---------	-----------------------

No welding current

mains switch is on, overtemperature indicator is lit up

Cause:	Overload; the duty cycle has been exceeded
--------	--

Remedy:	Do not exceed the duty cycle
---------	------------------------------

Cause:	Thermostatic cut-out system has tripped
--------	---

Remedy:	Wait until the power source automatically switches back on after the cooling phase has finished
---------	---

Cause:	The fan in the power source is faulty
--------	---------------------------------------

Remedy:	Replace the fan (After-Sales Service)
---------	---------------------------------------

No welding current

mains switch is on and indicators are lit up

Cause:	Grounding (earthing) connection is incorrect
--------	--

Remedy:	Check the earth (ground) connection and clamp for correct polarity
---------	--

Cause:	There is a break in the current cable in the welding torch
--------	--

Remedy:	Replace the welding torch
---------	---------------------------

Nothing happens when torch trigger is pressed

mains switch is on and indicators are lit up

Cause:	The control plug is not plugged in
--------	------------------------------------

Remedy:	Insert the control plug
---------	-------------------------

Cause:	Welding torch or welding torch control line defective
--------	---

Remedy:	Replace the welding torch
---------	---------------------------

No shielding gas

all other functions are OK

Cause:	The gas cylinder is empty
--------	---------------------------

Remedy:	Change the gas cylinder
Cause:	Gas pressure regulator is faulty
Remedy:	Change the gas pressure regulator
Cause:	The gas hose is not fitted or is damaged
Remedy:	Fit/change the gas hose
Cause:	The welding torch is faulty
Remedy:	Change the welding torch
Cause:	Gas solenoid valve is faulty
Remedy:	Replace gas solenoid valve

Poor weld properties

Cause:	Incorrect welding parameters
Remedy:	Check the settings
Cause:	Grounding (earthing) connection is incorrect
Remedy:	Check the earth (ground) connection and clamp for correct polarity

The welding torch becomes very hot

Cause:	The design dimensions of the welding torch are not sufficient for this task
Remedy:	Observe the duty cycle and loading limits

Care, maintenance and disposal

General

Under normal operating conditions, the power source requires only a minimum of care and maintenance. However, it is vital to observe some important points to ensure it remains in a usable condition for many years.

Safety



WARNING! An electric shock can be fatal. Before opening the device

- Turn the mains switch to the "O" position
- Unplug the machine from the mains
- Prevent it from being switched on again
- Using a suitable measuring instrument, check to make sure that electrically charged components (e.g. capacitors) have discharged



WARNING! Work that is carried out incorrectly can cause serious injury and damage. The following activities must only be carried out by trained and qualified personnel. All instructions in the section headed "Safety rules" must be observed.

At every start-up

- Check mains plug, mains cable, welding torch, interconnecting hosepack and grounding (earthing) connection for damage
- Check that there is a gap of 0.5 m (1 ft. 8 in.) all around the device to ensure that cooling air can flow and escape unhindered



NOTE! Air inlets and outlets must never be covered, not even partially.

Every 2 months

- If present: clean air filter
-

Every 6 months

- Dismantle device side panels and clean inside of device with dry reduced compressed air



NOTE! Risk of damage to electronic components. Do not bring air nozzle too close to electronic components.

- If a lot of dust has accumulated, clean the cooling air ducts.
-

Disposal

Dispose of in accordance with the applicable national and local regulations.

Appendix

Technical data

Special voltages The technical data on the rating plate applies to devices designed for special voltages.

TransTig 1750 Puls

Mains voltage			1 x 230 V
Mains voltage tolerance			-20 %/+15 %
Mains frequency			50 / 60 Hz
Mains fuse protection			16 A slow-blow
Mains connection ¹⁾			restrictions possible
Primary continuous power (100 % d.c. ²⁾)			3.8 kVA
Cos phi			0.99
Welding current range	TIG	2 - 170 A	
	Rod electrode	10 - 140 A	
Welding current at	10 min/40°C (104°F)	35%d.c. ²⁾	170 A
		100%d.c. ²⁾	120 A
Open circuit voltage (pulsed)			93 V
Working voltage	TIG	10.1 - 16.8 V	
	Rod electrode	10.3 - 25.6 V	
Striking voltage U _p			9.0 kV
The arc striking voltage is designed for manual operation			
Degree of protection			IP 23
Type of cooling			AF
Insulation class			A
EMC device class in accordance with EN/IEC 60974-10			A
Overvoltage category			III
Pollution level according to IEC60664			3
Ambient temperature			-10 °C - +40 °C
			+14 °F - +104 °F
Storage temperature			-25 °C - +55 °C
			-13 °F - +131 °F
Dimensions l x w x h			430 x 180 x 280 mm
			16.93 x 7.09 x 11.02 in.
Weight			9.1 kg
			20.06 lb.
Marks of conformity			CE
Safety symbol			S

1) to public mains with 230/400 V and 50 Hz

2) d.c. = duty cycle

Spare parts list

TransTig 1750 Puls 4,075,167
 TransTig 1750 Puls G/F nc 4,075,167,639

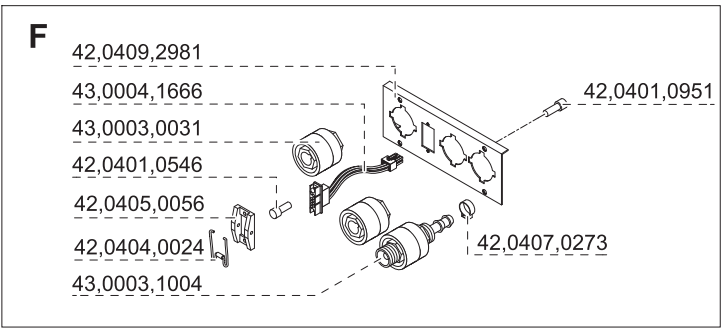
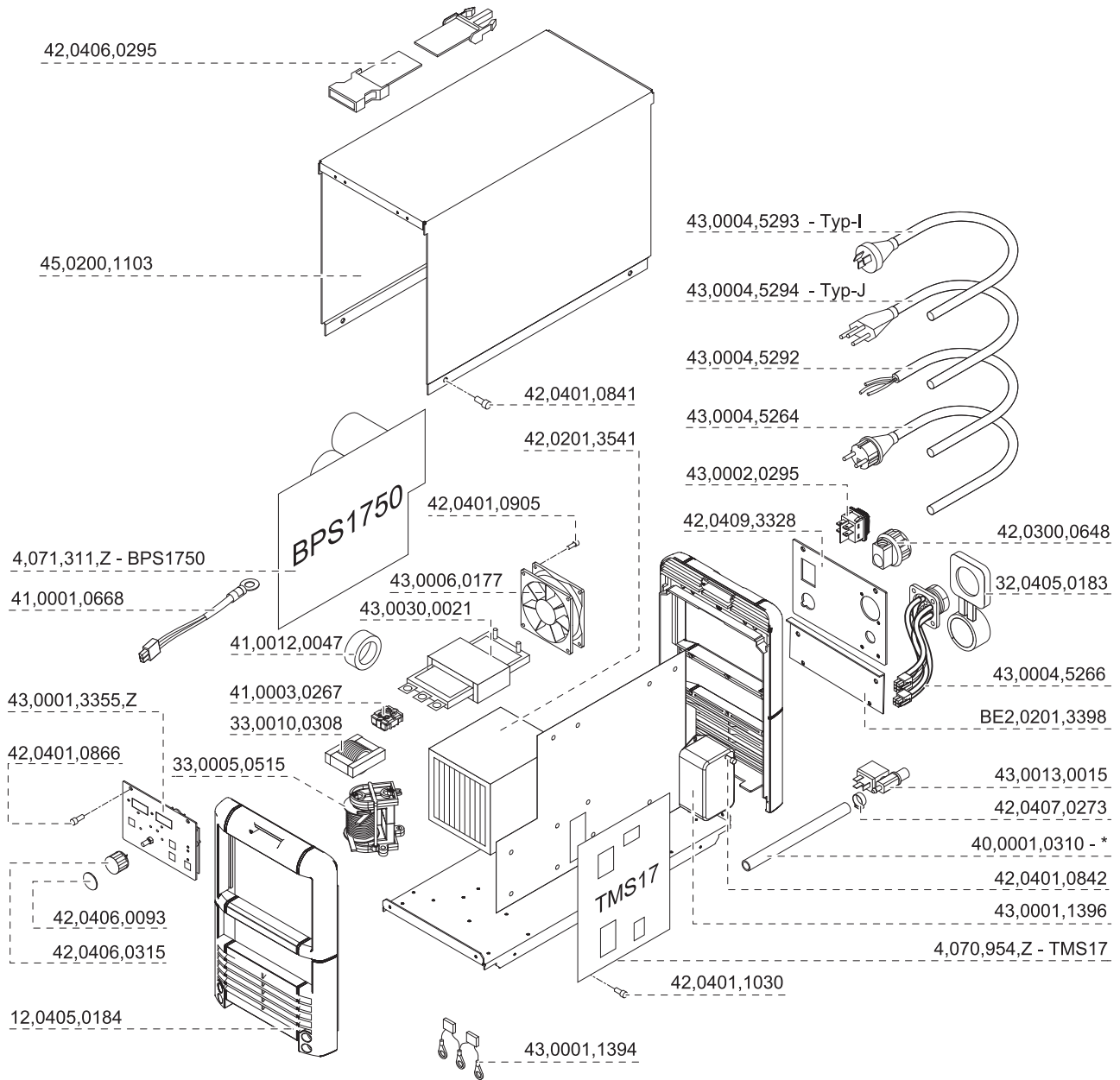

* gewünschte Länge angeben
 * Specify the length required
 * Indiquer la longueur désirée
 * Indicar la longitud deseada
 * Indicare la lunghezza desiderat
 * indicar o comprimento desejado
 * uved'te požadovanou délku

Circuit diagram

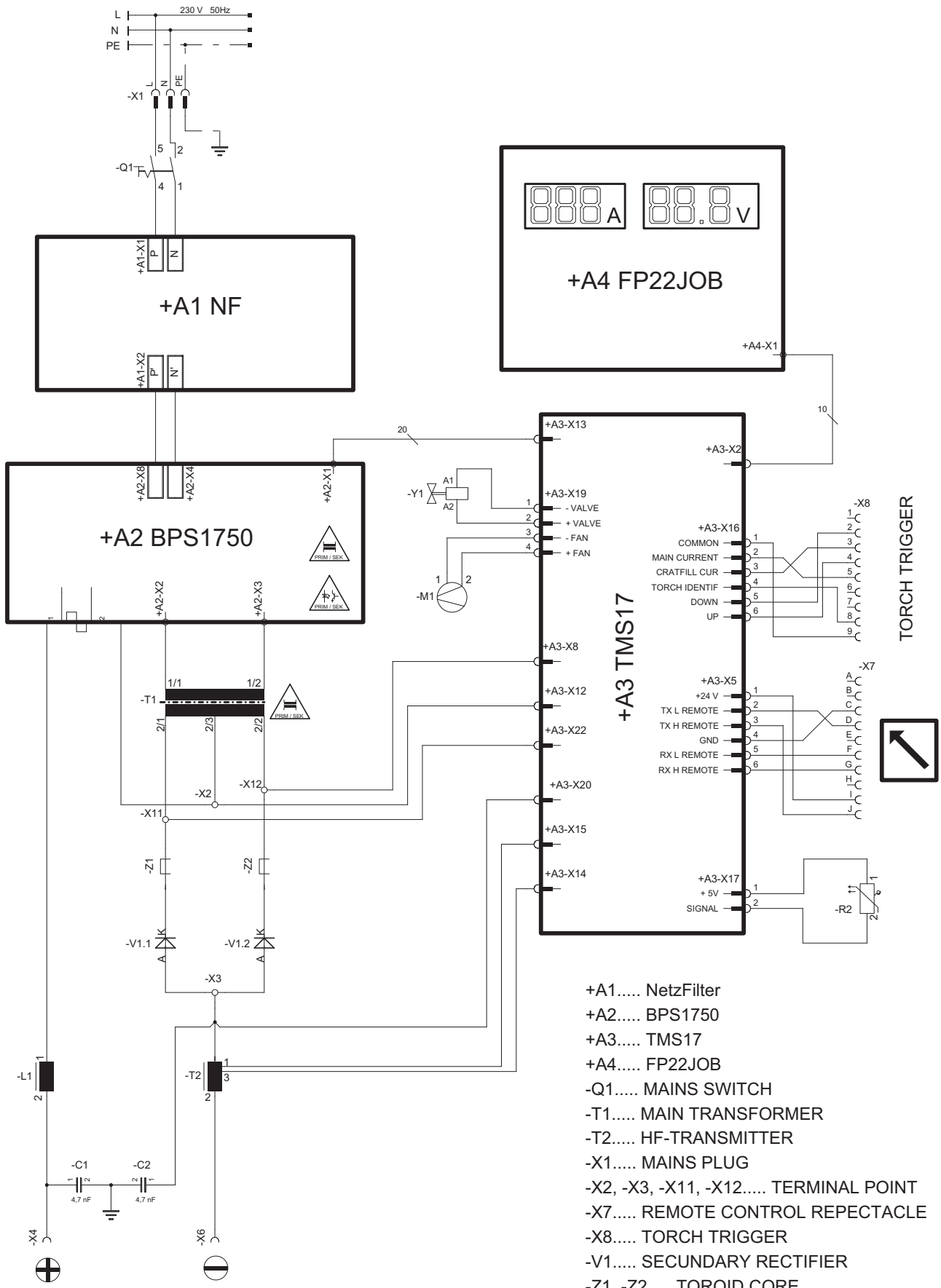

- +A1..... NetzFilter
- +A2..... BPS1750
- +A3..... TMS17
- +A4..... FP22JOB
- Q1..... MAINS SWITCH
- T1..... MAIN TRANSFORMER
- T2..... HF-TRANSMITTER
- X1..... MAINS PLUG
- X2, -X3, -X11, -X12..... TERMINAL POINT
- X7..... REMOTE CONTROL REPECTACLE
- X8..... TORCH TRIGGER
- V1..... SECONDARY RECTIFIER
- Z1, -Z2..... TOROID CORE



FRONIUS INTERNATIONAL GMBH

Froniusplatz 1, A-4600 Wels, Austria

Tel: +43 (0)7242 241-0, Fax: +43 (0)7242 241-3940

E-Mail: sales@fronius.com

www.fronius.com

www.fronius.com/addresses

Under <http://www.fronius.com/addresses> you will find all addresses
of our Sales & service partners and Locations